

EE03 Series

OEM Humidity / Temperature Module

alterations according to customer specifications possible

The EE03 is an inexpensive, highly accurate, temperature and humidity measurement module for OEM applications that communicates via a two-wire digital protocol. Originally designed and manufactured for the automotive industry, this device has excellent long-term stability and is ideal for a wide range of applications that require remote or embedded RH and temperature measurements.

The EE03 plug-in module design also allows for ambient air monitoring or measurement of surface humidity and temperature to detect near-condensation (dew point) conditions. For applications in salt air or harsh environments, the EE03 is also available with an optional protective coating.

The EE03 features an embedded microprocessor that retains calibration data, and provides a full-range, temperature corrected humidity output. The simple E2 digital protocol used by the EE03 allows for low-cost integration with other devices utilizing microprocessor based control or monitoring.



Typical Applications

HVAC & economizer control
automotive
appliances
consumer products
humidifiers
dehumidifiers
medical technology

Features

digital two wire output for RH and T
qualified for surface condensation monitoring
interchangeable plug-in design
integrated easily to systems
compact design
low power consumption
cable length up to 10m (32.8ft)
optional protective coating for harsh environments
traceable calibration

Technical Data

Measuring values

Relative Humidity

| | |
|--|---|
| Sensor | HC103 |
| Digital output (2 wires) ²⁾ | output value: 0.00...100.00% RH |
| Working range ¹⁾ | 0...95% RH with coating 0...100% RH |
| Accuracy at 21°C (70°F) | ±3% RH (10...100% RH) Traceable to intern. standards, administrated by NIST, PTB, BEV... |
| Temperature dependence | ±0.00035 x RH x (T-20°C) |

Temperature

| | |
|--|--|
| Digital output (2 wires) ²⁾ | Output value: -40.00...+85.00°C (-40.00...+185.00°F) |
| Accuracy at 20°C (68°F) | ±0.3°C (±0.54°F) |

General

| | | |
|-----------------------------------|---|---|
| Supply voltage SELV ³⁾ | 2.5V DC - 5.5V DC | SELV = Safety Extra Low Voltage |
| Current consumption | < 1.5mA | |
| Housing | ABS-PC / IP20 | |
| Electromagnetic compatibility | EN 61000-6-3 EN 61000-6-1 |  |
| Temperature range | working temperature: -40...85°C (-40...185°F) storage temperature: -40...60°C (-40...140°F) | |
| Maximum cable length | 10m (32.8ft) | |
| Electrical connections | designed for female connectors: AMP/TYCO / 0-0280359-0 (4 pins) and female crimp contacts: AMP/TYCO / 181270-1 | |

1) please refer to the working range of the HC103

2) serial protocol refer to www.epluse.com

3) max. permitted ripple: 20mV

Dimensions (mm) / Mounting

1 mm = 0.03937" / 1" = 25.4 mm

with mounting flange

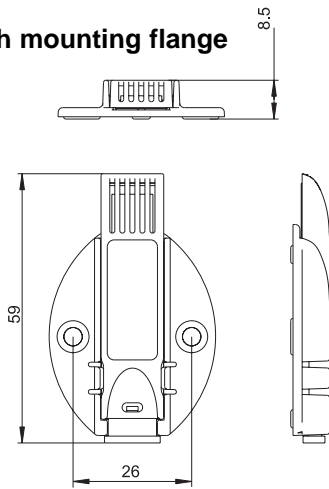

mounting by adhesive film
 for optimum temperature-offset
 (condensation monitoring)

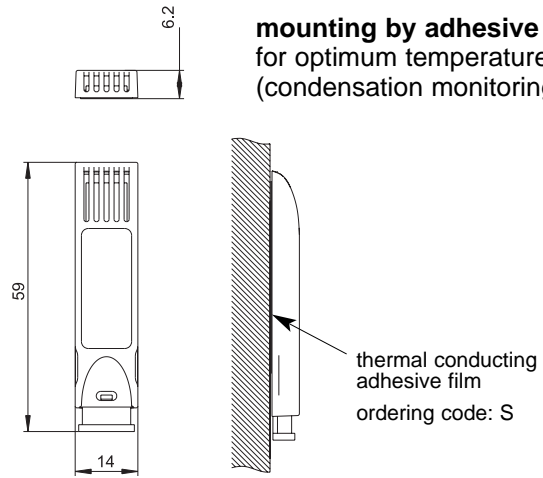

Connection diagram

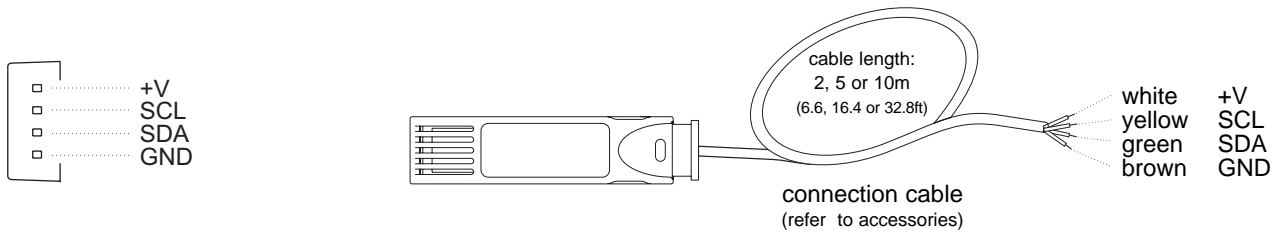

Ordering Guide

| MODEL | OUTPUT | ADHESIVE FILM | PROTECTIVE COATING |
|-------------------------------|------------------|-------------------------|--|
| humidity and temperature (FT) | E2-interface (9) | no (no code) yes (S) | without coating (no code) with coating (HC) |
| EE03- | | | |

Accessories

- E2-interface - RS232 converter: (HA011002)
 A RS232 converter is available for first testing measurements with a PC
- mounting set (plate, screws, dowel) (HA010206)
- connection cable 2m (6.6ft) (HA010307)
 5m (16.4ft) (HA010308)
 10m (32.8ft) (HA010309)

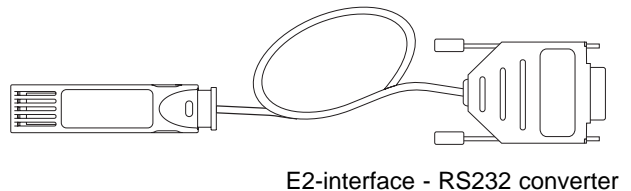

Order Example

EE03-FT9S

model: humidity and temperature
 output: E2-interface
 adhesive film: with adhesive film
 coating: without coating

EE03