

EE65 Series

Air Velocity Transmitter for HVAC Applications

EE65 air velocity transmitters are ideal for accurate ventilation control applications. They are operating on an innovative hot film anemometer principle.

The E+E thin film sensor guarantees very good accuracy at low air velocity, which is not possible for conventional anemometers with commercial temperature sensors or NTC bead thermistors.

Moreover, the E+E sensor is much more insensitive to dust and dirt than all other anemometer principles. This means high reliability and low maintenance costs.

EE65 series are available with current or voltage output, the measuring range and the response time can be selected with jumpers by the user.

Low angular dependence enables easy, cost-effective installation.

An integrated LC display and a version with remote sensing probe are available.



Typical Applications

HVAC
process and environmental control

Features

low angular dependence
easy installation
adjustable to application requirements

Technical Data

Measuring values

Working range ¹⁾	0...10m/s (0...2000ft/min) 0...15m/s (0...3000ft/min) 0...20m/s (0...4000ft/min)	
Output ¹⁾	0 - 10 V 4 - 20 mA	-1 mA < I _L < 1 mA R _L < 450 Ω
Accuracy at 20°C (68°F), 45 % RH and 1013hPa	0.2...10m/s (40...2000ft/min) 0.2...15m/s (40...3000ft/min) 0.2...20m/s (40...4000ft/min)	± (0.2m/s / 40ft/min + 3 % of m. v.) ± (0.2m/s / 40ft/min + 3 % of m. v.) ± (0.2m/s / 40ft/min + 3 % of m. v.)
Response time τ ₉₀ ^{1) 2)}	typ. 4 sec. or typ. 0.2 sec.	(at constant temperature)

General

Power supply	SELV 24V AC/DC ± 20 %	SELV = Safety Extra Low Voltage
Current consumption for AC supply	max. 150 mA	
for DC supply	max. 90 mA	
Angular dependence	< 3 % of measurement at Δα < 10°	
Cable gland	M16x1.5 cable Ø 4.5 - 10 mm (0.18 - 0.39")	
Electrical connection	screw terminals max. 1.5 mm ² (AWG 16)	
Electromagnetic compatibility	EN 50081-1 EN 50082-1 EN 50082-2	
Housing/protecting class	Polycarbonat / IP65, Nema 4	with LC display IP40

1) Selectable by jumper

2) Response time τ₉₀ is measured from the beginning of a step change of air velocity to the moment of reaching 90% of the step.



Temperature range	working temperature probe	-25...50°C (-13...122°F)
	working temperature electronic	-10...50°C (14...122°F)
	storage temperature	-30...60°C (-22...140°F)

Dimensions (mm)

1 mm = 0.03937" / 1" = 25.4 mm

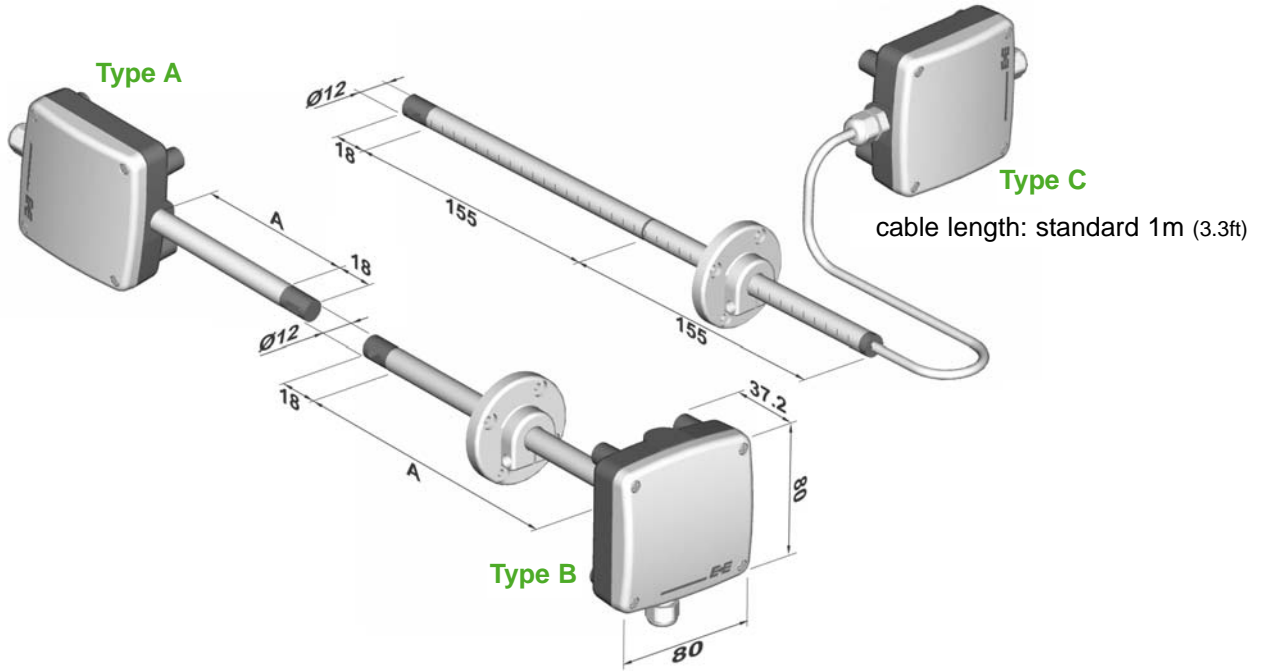

Connection Diagram

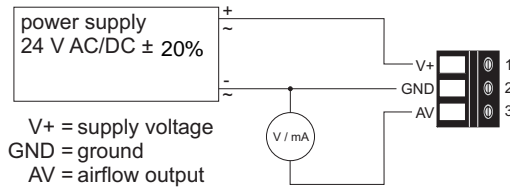

Ordering Guide

MODEL	HOUSING	PROBE LENGTH (according to "A")	CABLE LENGTH (Type C only)	DISPLAY
velocity (V)	wall mounting (A)	100mm (3.9") (3)	1m (3.3ft) (no code)	without display (no code)
	duct mounting (B)	200mm (7.9") (5)	2m (6.6ft) (K200)	with display (D02)
	remote sensor probe (C)	others (x)	5m (16.4ft) (K500) 10m (32.8ft) (K1000)	
EE65-				

Order Example

EE65-VB5-D02

model:	velocity
housing:	duct mounting
probe length:	200mm (7.9")
display:	with LC display