

EE14 Series

Hygrostats for Wall and Duct Mounting Applications

The EE14 hygrostat is based on the well proved E+E humidity sensors of the HC series, which guarantee excellent long term stability, low hysteresis and high resistance to pollutants. The switching threshold is freely adjustable in the range of 10...95% RH with a hysteresis which can be set independently between 3% and 15% RH.

EE14 hygrostat is available for wall or duct mounting, the right choice of protection filter cap enables maintenance free function in heavily polluted environment.

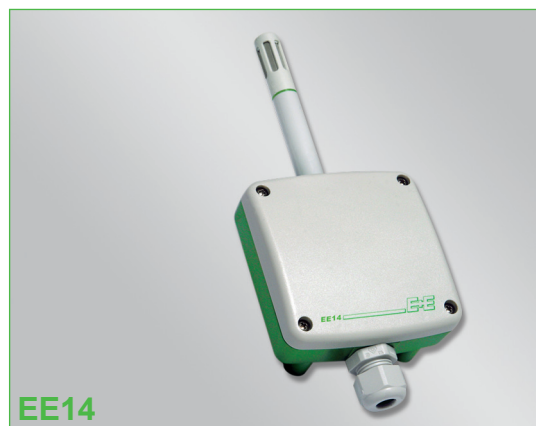

Typical Applications

- refrigeration
- swimming halls
- climate- and ventilation controls

Features

- maintenance free operation
- easy adjustment via poti
- working range 10...95% RH
- wettable

Working Principle

With a potentiometer it is possible to adjust the threshold between 10 and 95% RH. A second potentiometer is setting the switching-hysteresis between 3 and 15% RH.

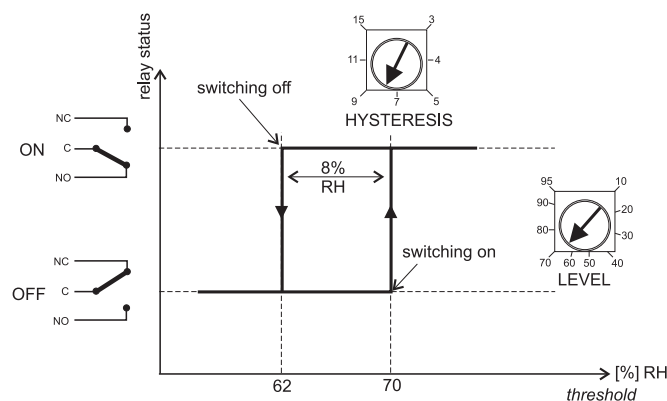

Connection Diagram

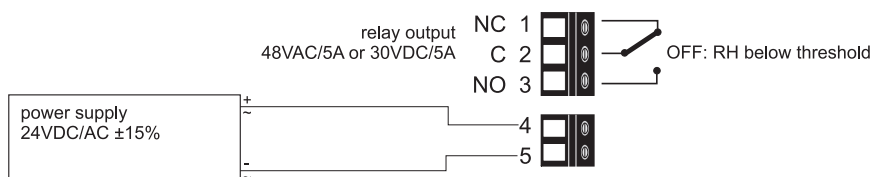

Technical Data

Measuring value

Humidity sensor	HC101	
Output	centre-zero relay up to 30V DC / 5A or 48V AC / 5A	
	threshold	hysteresis
Setting range	10...95% RH	3...15% RH
Setting accuracy	± 3% RH	

General

Supply voltage	24V DC / V AC ± 15 %	
Current consumption for DC supply	typ. 12 mA	
for AC supply	typ. 20 mA _{eff}	
Electrical connection	screw terminals max. 1.5 mm ² (AWG 16)	
Housing/ protection class	Polycarbonat / IP65, Nema 4	
Cable gland	M16x1.5; cable Ø 4.5 - 10 mm (0.18 - 0.39")	
Sensor protection	membrane filter, metal grid filter	
Electromagnetic compatibility	EN 50081-2	EN 50081-1
	EN 50082-2	
Temperature range	working temperature:	-5...50°C (23...122°F)
	storage temperature:	-30...60°C (-22...140°F)



Housing Dimensions (mm)

1 mm = 0.03937"/ 1" = 25.4 mm

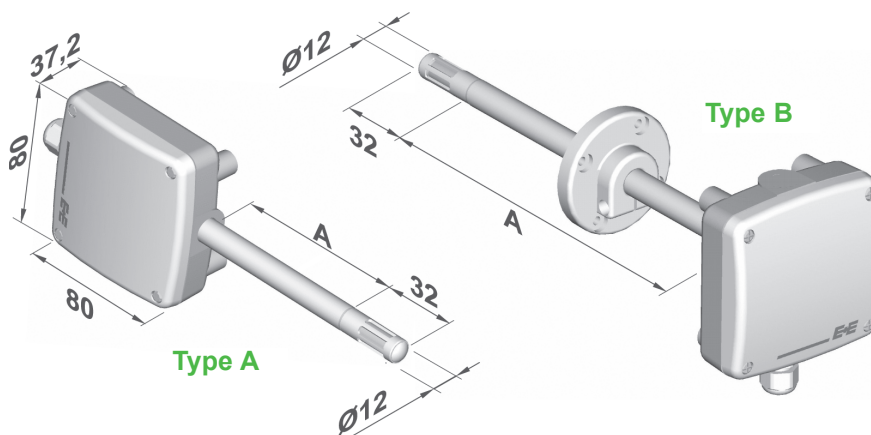

Ordering Guide

HOUSING		PROBE LENGTH (according to "A")		FILTER
wall mounting	(A)	20 mm (0.7")	(1)	membrane filter (1)
duct mounting	(B)	200 mm (7.9")	(5)	metal grid filter (6)
EE14-				

Order Example

EE14-A1

housing: wall mounting
 probe length: 20 mm (0.7")
 filter: membrane filter