

QUICK GUIDE

EE260 - Humidity and Temperature Probe for Meteorological Applications

(Full User Manual at www.epluse.com/EE260)

Electrical Connection



Important note:

The manufacturer cannot be held responsible for personal injuries or damage to property as a result of incorrect handling, installation, wiring, power supply and maintenance of the device.

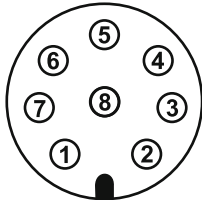

M12 device plug front view

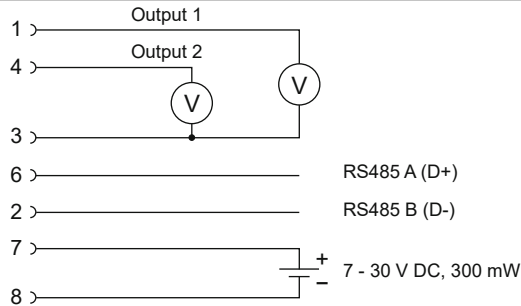

Pin number	Function	Wire colours for accessory: - Connection cable HA010322/23/24/25
1	Analogue output 1, voltage	white
2	RS485 B (D-)	brown
3	GND analogue output	green
4	Analogue output 2, voltage	yellow
5	n.c.	grey
6	RS485 A (D+)	pink
7	Supply voltage	blue
8	GND	red



Please note:

To meet the EMC Directive 2004/108/EC a shielded connection cable must be used.
 Compliance with EN61000-4-3 and EN 610004-6: Electromagnetic interferences may cause additional deviations <2 % RH.

Modbus Setup

Factory default setup:

Baudrate	Data	Parity	Stop bits	Modbus address
9600	8	Even	One	235

Modbus address, baud rate, parity and stop bits can be set via:

1. PCS10, Product Configuration Software, the Modbus configuration adapter HA011018 and the EE260 configuration cable HA011020. The PCS10 can be downloaded free of charge from www.epluse.com/PCS10.
2. Modbus protocol in the registers 60001 (0x00) and 60002 (0x01). See Application Note Modbus AN0103 (available on www.epluse.com/EE260)

Installation



Please note:

The probe shall be mounted vertically with the filter cap upside, a proper air circulation around the probe must be ensured (e.g. with HA010511). Please avoid any improper mechanical stress onto the probe.



Mounting in a radiation shield
 Accessory HA010511



Wall/pole mount by means of a mounting clip
 Accessory HA010227

Avoid unnecessary stress here

60 mm (2.4") clamping zone

Modbus Register Map

FLOAT 32 bit:				
Parameter name	Unit	Register number ¹⁾ [Dec]	Register address ²⁾ [HEX]	
Read register: function code 0x03 / 0x04				
Temperature T	°C	1003	0x3EA	
	°F	1005	0x3EC	
Relative humidity RH, Uw	% RH	1021	0x3FC	
	mbar	1101	0x44C	
Water vapour partial pressure e	psi	1103	0x44E	
	°C	1105	0x450	
Dew point temperature Td	°F	1107	0x452	
	°C	1109	0x454	
Wet bulb temperature Tw	°F	1111	0x456	
	g/m ³	1113	0x458	
Absolute humidity dv	gr/ft ³	1115	0x45A	
	g/kg	1121	0x460	
Mixing ratio r	gr/lb	1123	0x462	
	kJ/kg	1125	0x464	
Specific enthalpy h	BTU/lb	1129	0x468	
	°C	1131	0x46A	
Frost point temperature Tf	°F	1133	0x46C	
	ppm	1151	0x47E	
Volume concentration Wv	mbar	1221	0x4C4	
	psi	1223	0x4C6	
Saturation vapor pressure above water ew	mbar	1225	0x4C8	
	psi	1227	0x4CA	
Saturation vapor pressure above ice ei	°C	1237	0x4D4	
	°F	1239	0x4D6	
Ice bulb temperature Ti	g/kg	1247	0x4DE	
	gr/lb	1249	0x4E0	
INTEGER 16 bit:				
Parameter	Unit	Scale ³⁾	Register number ¹⁾ [Dec]	Register address ²⁾ [HEX]
Read register: function code 0x03 / 0x04				
Temperature T	°C	100	4002	0xFA1
	°F	50	4003	0xFA2
Relative humidity RH, Uw	% RH	100	4011	0xFAA
	mbar	10	4051	0xFD2
Water vapour partial pressure e	psi	1000	4052	0xFD3
	°C	100	4053	0xFD4
Dew point temperature Td	°F	100	4054	0xFD5
	°C	100	4055	0xFD6
Wet bulb temperature Tw	°F	100	4056	0xFD7
	g/m ³	10	4057	0xFD8
Absolute humidity dv	gr/ft ³	10	4058	0xFD9
	g/kg	10	4061	0xFDC
Mixing ratio r	gr/lb	10	4062	0xFDD
	kJ/kg	1	4063	0xFDE
Specific enthalpy h	BTU/lb	1	4065	0xFE0
	°C	100	4066	0xFE1
Frost point temperature Tf	°F	100	4067	0xFE2
	ppm	0.1	4076	0xFEB
Volume concentration Wv	mbar	100	4111	0x100E
	psi	100	4112	0x100F
Saturation vapor pressure above water ew	mbar	100	4113	0x1010
	psi	100	4114	0x1011
Saturation vapor pressure above ice ei	°C	100	4119	0x1016
	°F	100	4120	0x1017
Ice bulb temperature Ti	g/kg	10	4124	0x101B
	gr/lb	10	4125	0x101C

1) Register number starts from 1 2) Register address starts from 0

3) Examples: For scale 100, the reading of 2550 means a value of 25.5. For scale 50, the reading of 2550 means a value of 51.

INFORMATION

+43 7235 605 0 / info@epluse.com

E+E Elektronik Ges.m.b.H.
Langwiesen 7 • 4209 Engerwitzdorf • Austria
Tel: +43 7235 605-0 • Fax: +43 7235 605-8
info@epluse.com • www.epluse.com

LG Linz Fn 165761 t • VAT No. ATU44043101
Place of Jurisdiction: 4020 Linz • DVR0962759

