



OPERATING MANUAL

EE36
MOISTURE IN OIL SENSOR
FOR MARITIME APPLICATIONS



E+E Elektronik Ges.m.b.H. doesn't accept warranty and liability claims neither upon this publication nor in case of improper treatment of the described products.

The document may contain technical inaccuracies and typographical errors. The content will be revised on a regular basis. These changes will be implemented in later versions. The described products can be improved and changed at any time without prior notice.

© Copyright E+E Elektronik Ges.m.b.H.
All rights reserved.

USA

FCC notice:

This equipment has been tested and found to comply with the limits for a Class B digital device, pursuant to part 15 of the FCC Rules. These limits are designed to provide reasonable protection against harmful interference in a residential installation. This equipment generates, uses and can radiate radio frequency energy and, if not installed and used in accordance with the installation manual, may cause harmful interference to radio communications. However, there is no guarantee that interference will not occur in a particular installation. If this equipment does cause harmful interference to radio or television reception, which can be determined by turning the equipment off and on, the user is encouraged to try to correct the interference by one or more of the following measures:

- Reorient or relocate the receiving antenna.
- Increase the separation between the equipment and receiver.
- Connect the equipment into an outlet on a circuit different from that to which the receiver is connected.
- Consult the dealer or an experienced radio/TV technician for help.

CANADIAN

ICES-003 Issue 5:

CAN ICES-3 B / NMB-3 B

TABLE OF CONTENTS

1	GENERAL	4
1.1	Explanation of symbols	4
1.2	Safety instructions	4
1.2.1	General safety instructions	4
1.2.2	Mounting, start-up and operation	4
1.2.3	Safety instructions for use of the alarm module with voltages >50V	5
1.3	Environmental aspects	5
2	PRODUCT DESCRIPTION	5
3	INSTALLATION	6
3.1	Installation of the housing.....	6
3.2	Installation of the probe	6
3.2.1	General safety instructions for installation	6
3.2.2	Installation of the probe directly in the process.....	7
3.2.3	Installation of the probe with the ball valve set	8
4	ELECTRICAL CONNECTIONS	10
4.1	Connection diagram	10
4.2	Alarm module connection diagram.....	10
4.3	Connection options C03/C06/C07.....	10
4.4	Wire assignment interface cable RS232	10
5	OPERATING COMPONENTS	11
5.1	Circuit board	11
5.2	Display option.....	12
6	ALARM MODULE	13
7	HUMIDITY/TEMPERATURE CALIBRATION	14
7.1	2-point humidity calibration.....	14
7.1.1	2-point humidity calibration procedure on the circuit board:	14
7.2	2-point temperature calibration.....	15
7.2.1	2-point temperature calibration procedure on the circuit board:	16
7.3	1-point humidity calibration.....	17
7.3.1	1-point humidity calibration procedure on the circuit board:	17
7.4	1-point temperature calibration	18
7.4.1	1-point temperature calibration procedure on the circuit board:	18
7.5	Return to factory calibration	19
8	MAINTENANCE	19
8.1	Sensor cleaning.....	19
8.2	Sensor replacement	19
8.2.1	Sensor replacement of pluggable sensors.....	20
8.2.2	Sensor replacement of soldered sensors	20
8.3	Probe replacement	21
8.3.1	Probe replacement procedure:	21
8.4	Self diagnostics and error messages	21
8.4.1	Self diagnostics via LEDs on the circuit board:.....	21
8.4.2	Self diagnostics via display (where available):.....	21
8.4.3	Definitions:	21
8.5	Replacement of sealing element	22
9	SCOPE OF SUPPLY	22
10	REPLACEMENT PARTS / ACCESSORIES	22
11	TECHNICAL DATA	23

1 GENERAL

This operation manual is part of the scope of supply and serves for ensuring proper handling and optimal functioning of the device.

The operation manual shall be read before commissioning the equipment and it shall be provided to all staff involved in transport, installation, operation, maintenance and repair.

The operation manual may not be used for the purposes of competition without the written consent of E+E Elektronik® and may not be forwarded to third parties. Copies may be made for internal purposes. All information, technical data and diagrams included in these instructions are based on the information available at the time of writing.

1.1 Explanation of symbols



This symbol indicates safety information.

It is essential that all safety information is strictly observed. Failure to comply with this information can lead to personal injuries or damage to property. E+E Elektronik® assumes no liability if this happens.



This symbol indicates instructions.

The instructions shall be observed in order to reach optimal performance of the device.

1.2 Safety instructions

1.2.1 General safety instructions

- Avoid any unnecessary mechanical stress and inappropriate use.
- When replacing the filter cap make sure not to touch the sensing elements.
- For sensor cleaning please see “Cleaning instructions” at www.epluse.com.
- Installation, electrical connection, maintenance and commissioning shall be performed by qualified personnel only.

1.2.2 Mounting, start-up and operation

The humidity / temperature transmitter has been produced under state of the art manufacturing conditions, has been thoroughly tested and has left the factory fulfilling all safety criteria.

The manufacturer has taken all precautions to ensure safe operation of the device. The user must ensure that the device is set up and installed in a manner that does not have a negative effect on its safe use.

The user is responsible for observing all applicable safety guidelines, local and international, with respect to safe installation and operation on the device. This operating manual contains information and warnings that must be observed by the user in order to ensure safe operation.

- Mounting, start-up, operation and maintenance of the device may be performed by qualified staff only. Such staff must be authorized by the plant operator to carry out the mentioned activities.
- The qualified staff must have read and understood this operating manual and must follow the instructions contained within.
- All process and electrical connections shall be thoroughly checked by authorized staff before putting the system into operation.
- Do not install or start start-up a device supposed to be faulty. Make sure that such devices are not accidentally used by marking them clearly as faulty.
- A faulty device may only be investigated and possibly repaired by qualified, trained and authorized staff. If the fault cannot be fixed, the device shall be removed from the system.
- Service operations other than described in this operating manual may only be performed by the manufacturer.

1.2.3 Safety instructions for use of the alarm module with voltages >50V

- To insulate the optional alarm module from the low-voltage side of the transmitter, the partition provided for this purpose must be fitted in the lower section.
- During operation of the instrument the modular housing must be completely closed.
- The protection class of an opened housing corresponds to IP00 and direct contact with components carrying dangerous voltages is therefore possible. In general, work on live components should be avoided and when absolutely necessary, should be performed by qualified personnel only.

Disclaimer

The manufacturer or his authorized agent can be only be held liable in case of willful or gross negligence. In any case, the scope of liability is limited to the corresponding amount of the order issued to the manufacturer. The manufacturer assumes no liability for damages incurred due to failure to comply with the applicable regulations, operating instructions or the operating conditions. Consequential damages are excluded from the liability.

1.3 Environmental aspects



Products from E+E Elektronik® are developed and manufactured observing of all relevant requirements with respect to environment protection. Please observe local regulations for the device disposal.



For disposal, the individual components of the device must be separated according to local recycling regulations. The electronics shall be disposed of correctly as electronics waste.

2 PRODUCT DESCRIPTION

The EE36 is specially designed for the measurement of moisture in oil in maritime applications. The measured and the calculated values are available on two free scaleable and configurable analogue outputs. In addition, an optional relay output can be used for alarms and process control.

The modular housing enables a user-friendly operation and a quick replacement of the sensor unit for service purposes.

The construction of the transmitter makes field and local loop calibration an easy task.



DNV GL-Approval:

The EE36 is certified in accordance with the "Germanischer Lloyd (DNV GL)".

3 INSTALLATION

3.1 Installation of the housing

Drilling with round hole:

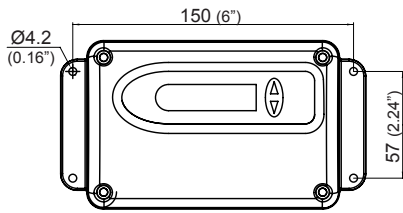

Drilling with long hole:

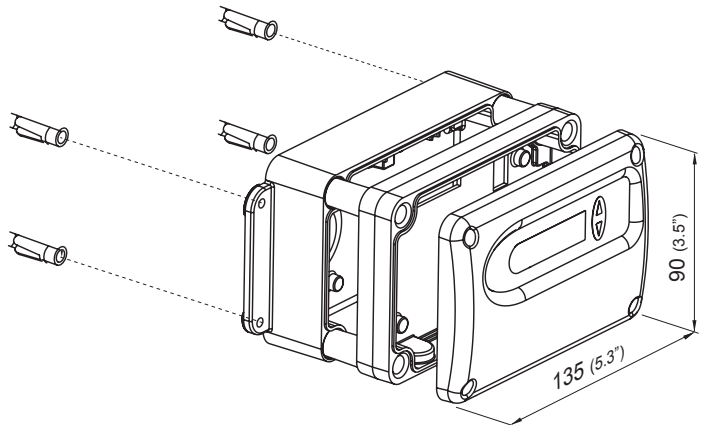
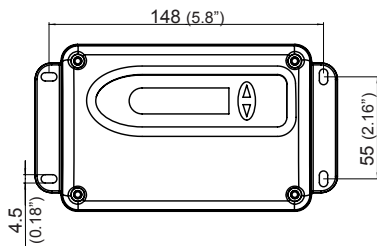

3.2 Installation of the probe

Select a location with environmental conditions according to the technical specs. The measuring medium (oil) shall be as clean as possible i.e. without contamination.



The probe cable (connection between sensing probe and basic device) may not be shortened or extended. Correct functioning of the transmitter is only guaranteed with the original probe cable.

3.2.1 General safety instructions for installation



Because the sensing probe can be exposed to very high pressure, there is the risk of sudden, unintentional expulsion of the probe during or after improper installation. Therefore, special precautions should be taken when working on the sensing probe or in its vicinity. Bending over the sensing probe shall be avoided under any circumstances!

During the installation of the sensor probe, make sure that the surface of the sensing probe is not damaged! Damaging the probe could lead to damaged seals (consequence: leakage and pressure loss) and to problems during removal (jamming).

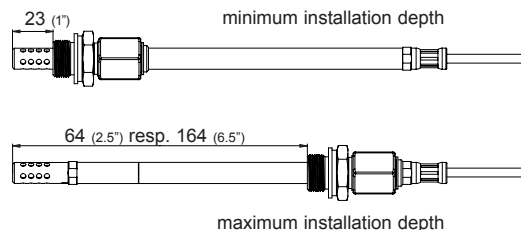
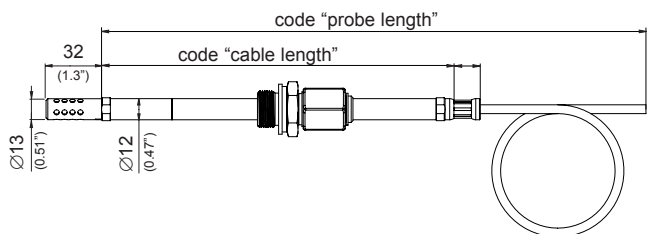

3.2.2 Installation of the probe directly in the process

For direct probe installation, a stop valve should be provided on both sides of the probe insert. This allows the sensor probe to be removed for maintenance and calibration without any problems.

If the probe is installed in a pressure chamber, make sure that the pressure in the chamber and the ambient pressure are in equilibrium before you remove the probe.

INSTALLATION OF THE PROBE:

The temperature during installation may not vary more than $\pm 40^{\circ}\text{C}$ ($\pm 72^{\circ}\text{F}$) from the operating temperature.

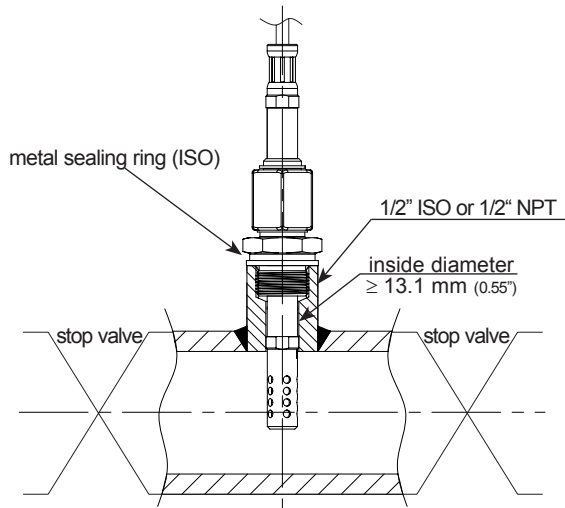

1st step:

Close the valves.

2nd step:

Insert the sensor probe into the process.

3rd step:

To ensure a secure installation of the probe, the lock nut must be tightened with a torque of 30 Nm. If no torque-spanner is available tighten the lock nut by hand as good as possible. Continue to turn with an open-ended spanner $\sim 50^{\circ}$.

3.2.3 Installation of the probe with the ball valve set

The ball valve set allows for the removal of the probe without interrupting the process.

Install the ball valve perpendicular to the direction of flow.

The pressure of the oil must be less than 20 bar (290psi).

The two metal sealing rings (see figure) should be replaced every time prior to re-installing the probe.

INSTALLATION OF THE PROBE:

The temperature during installation may not deviate more than $\pm 40^{\circ}\text{C}$ ($\pm 72^{\circ}\text{F}$) from the operating temperature.

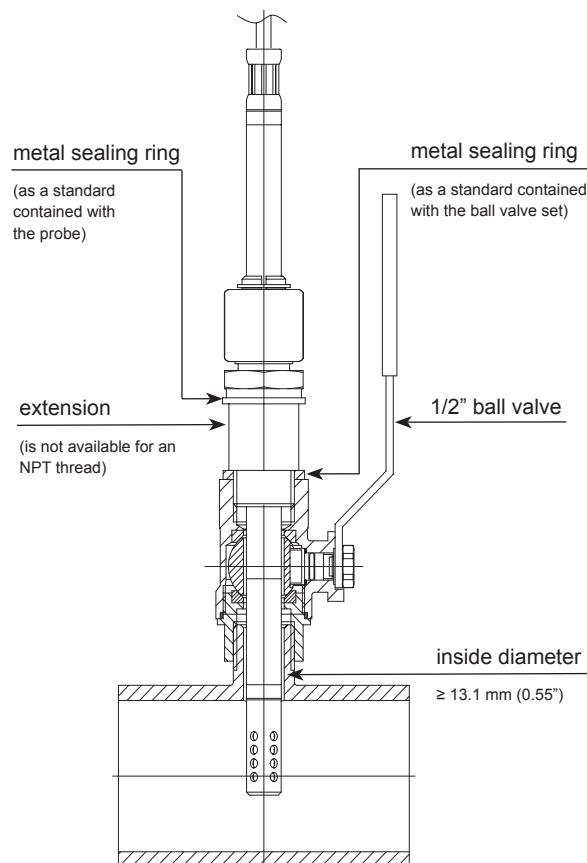

1st step:

Install the probe while the ball valve is closed.

2nd step:

Open the ball valve.

3rd step:

Slide the probe through the ball valve into the oil. A manual pressing tool is recommended at high pressure.

4th step:

To ensure a secure installation of the probe, the lock nut must be tightened with a torque of 30 Nm. If no torque-spanner is available tighten the lock nut by hand as good as possible. Continue to turn with an open-ended spanner $\sim 50^{\circ}$.



A too low torque results in a smaller tension force (fixing force) on the clamping sleeve. There is the risk of injury due to sudden expulsion of the sensing probe. A too high torque can lead to permanent deformation of the clamping sleeve and the sensing probe. This can make the removal and re-installation difficult or impossible.

REMOVING OF THE PROBE:

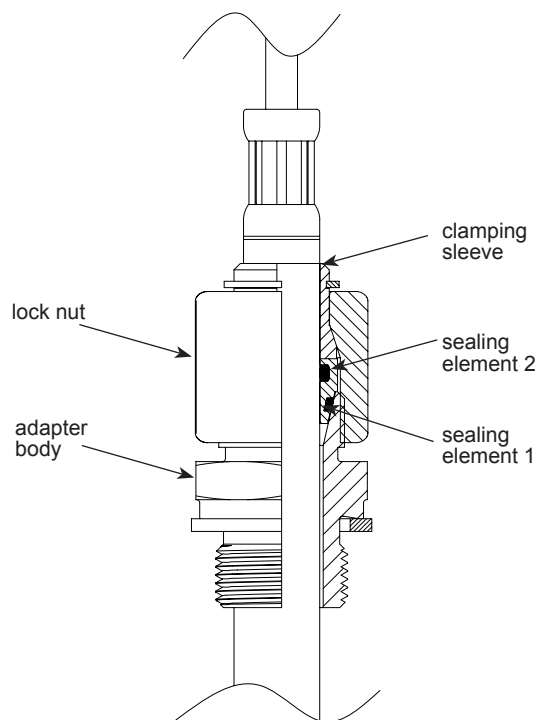

1st step:
Firmly hold sensing probe. (Attention: do not bend connection cable)

2nd step:
Slowly loosen the lock nut with a spanner (spanner width 24) until the expulsion force acts on the probe.



In the installed state, never completely remove the lock nut, only unscrew it as much as necessary!

3rd step:
After the sensing head has been pushed out of the process up to the stop, close the ball valve.

4th step:
The probe can now be completely removed.



Observe the correct positioning of the sealing element 1 while mounting or removing the probe.

4 ELECTRICAL CONNECTIONS

4.1 Connection diagram

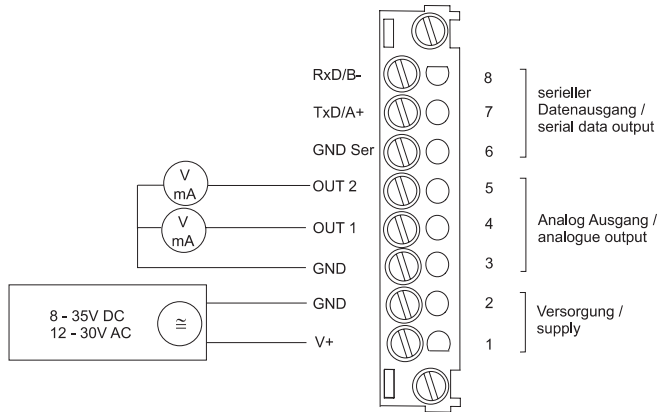

4.2 Alarm module connection diagram



4.3 Connection options C03/C06/C07

Plug for supply and analogue output (front view)

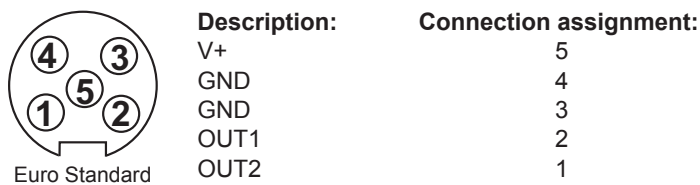

Plug for RS232 connection (front view)

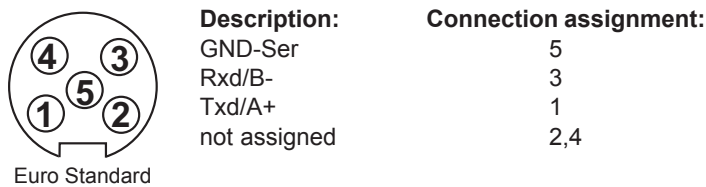

Observe the pin numbers stamped in the plug as shown in the above drawings!

4.4 Wire assignment interface cable RS232

Cable:	Description:
yellow	GND
brown	TXD
white	RXD

5 OPERATING COMPONENTS

5.1 Circuit board

After removal of the housing cover, the following operating components on the circuit board may be accessed for transmitter setup.

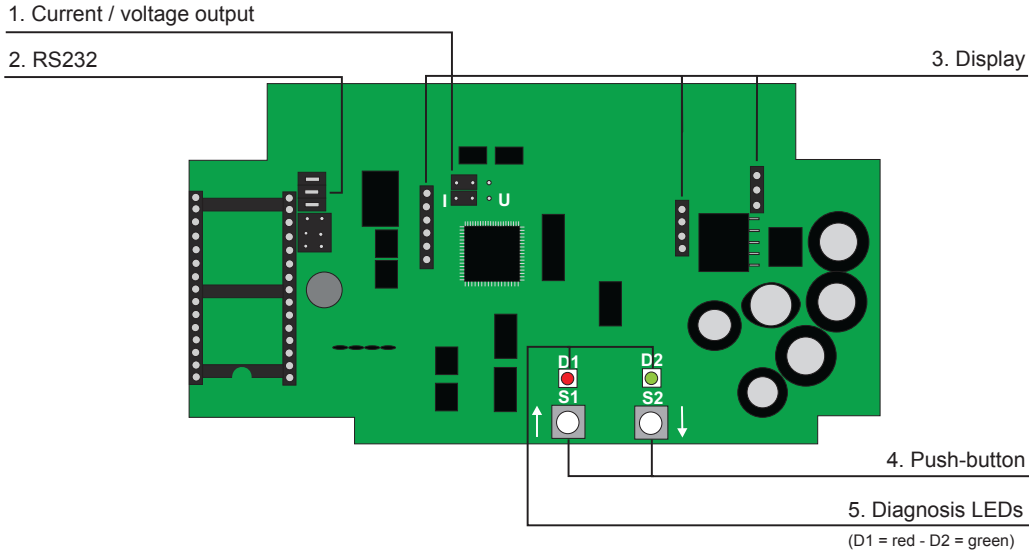

1. Current / voltage output:

If the device is switched from current to voltage output using the configuration software the two jumpers must be located as follows:

for current signals:



for voltage signals:



2. RS232

Serial interface for configuration of the EE36.

3. Display

Connectors for optional display.

4. Push-Buttons for calibration purposes

See chapter 7 "Humidity/Temperature calibration"

5. Diagnosis LEDs

See chapter 7 "Humidity/Temperature calibration" ,and chapter 8.4 "Self diagnosis and error messages"

5.2 Display option

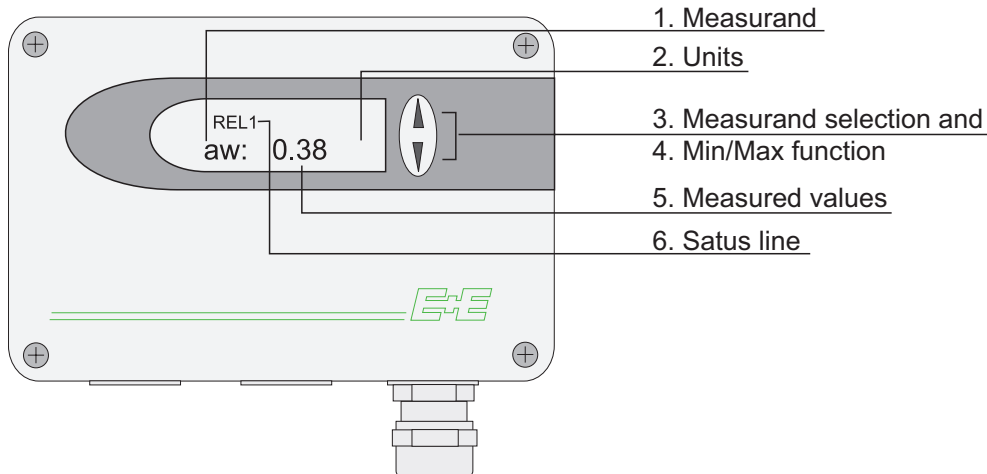

1. MEASURAND:		2. UNITS:		3. MEASURAND SELECTION:
SI		SI	US	Press the ▲ or ▼ button to select the desired measurand
T	Temperature	°C	°F	
aw	Water activity			
x	Water content	ppm	ppm	

4. MIN / MAX FUNCTION:

Transmitters of the EE36 series can display the highest and lowest measured value measured since the last reset.

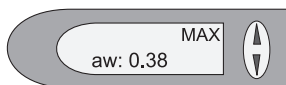

Highest measured value:

1. Select the desired measurand.
2. To display the maximum value of the selected measurand, press the ▲ button for at least five seconds.
- 3.1 To reset the instrument to its normal operating status, press the ▲ button once again for five seconds.
- 3.2 If both buttons are pressed for at least five seconds while the maximum value is displayed → the "MAX" symbol disappears → the maximum value will be deleted (Reset).

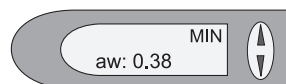

Lowest measured value:

1. Select the desired measurand.
2. To display the minimum value of the selected quantity, press the ▼ button for at least five seconds.
- 3.1. To reset the instrument to its normal operating status, press the ▼ button once again for five seconds.
- 3.2. If both buttons are pressed for at least five seconds while the minimum value is displayed → the "MIN" symbol disappears → the minimum value will be deleted (Reset).

5. MEASURED VALUES:

The dominant value of the appropriate quantity is displayed in this field. For the factory configuration, the measured values may fall between the measurement ranges shown below.

		from	up to	unit
Water activity	aw	0	1	
Temperature	T	-40 (-40)	180 (356)	°C (°F)
Water content	x	0	100,000	ppm

The measurement ranges indicated above can be set to individual requirements using the configuration software (see software manual; chapter 5 "Index - Index Cards").

6. STATUS LINE:

- MIN; MAX: see point "MIN/MAX Function"
- CALIB LOW; CALIB HIGH: indicates the low or high humidity/temperature calibration point.
- REL1 / REL2: Status Relay
- "ERROR 01....04": see Hardware, chapter 8.3 "Self-diagnosis and error messages"

6 ALARM MODULE

The optional alarm module can be used for alarm and basic control functions. The module can be configured via Software, using the EE-PCA Product Configuration Adapter (see datasheet at www.epluse.com/ee-pca) and EE-PCS Product Configuration Software (free download from www.epluse.com/configurator)

The user thus has the option of setting the measurand to be monitored (aw, x, T) and the threshold and hysteresis for each relay.

max. switched voltage / max. switched current: 250 VAC / 6A

28 VDC / 6A

Minimum load: >100mA / 12V

Relay 1:

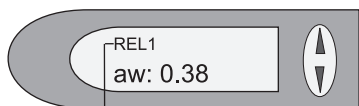

If relay 1 has tripped (ON), then REL1 is displayed.

Relay 2:

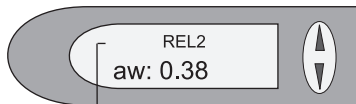

If relay 2 has tripped (ON), then REL2 is displayed.

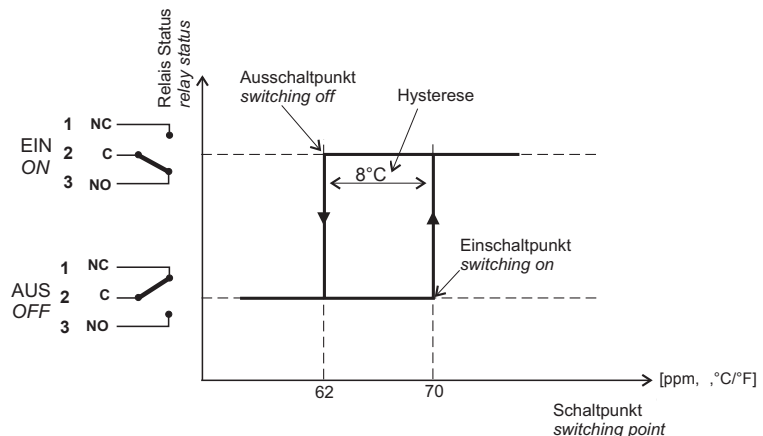

7 HUMIDITY/TEMPERATURE CALIBRATION

The sensor EE36 can be calibrated in two ways:

- via Software, using the EE-PCA Product Configuration Adapter (see datasheet at www.epluse.com/ee-pca) and EE-PCS Product Configuration Software (free download from www.epluse.com/configurator)
- with push-buttons on the electronics board, see below.

1-point humidity/temperature calibration:

Quick and simple calibration on a defined humidity/ temperature point (working point).

2-point humidity/temperature calibration:

simple calibration for accurate measuring results over the whole humidity/temperature working range.



- To reach a temperature balance it is recommended to keep the transmitter and the reference chamber (e.g. HUMOR 20,...) for minimum 4 hours in the same room.
- During stabilisation period and calibration procedure it is important to keep the temperature constant in the reference climate chamber.
- For calibration the humidity sensor probe must be stabilised at least 20 minutes in the reference chamber.
- Replace a dirty filter cap before calibration!
- A reduction of the stabilisation time can be achieved by cleaning the probe with n-Hexan resp. n-Heptan. Sway the probe carefully in the solvent then drip off and after that exhaust the air around the probe >0.5h.
- Attention: Other solvents than above mentioned can corrode the humidity sensor!

7.1 2-point humidity calibration

For accurate adjustment over the whole working range a two point calibration is recommended.



- Start calibration at the low humidity calibration point!
- The humidity difference between the two points should be > 30%RH
- Low humidity point < high humidity point
- 2-point calibration may be performed directly on the circuit board or using the configuration software supplied (for more details, see Configuration Software, chapter 5.4 "Calibration")

7.1.1 2-point humidity calibration procedure on the circuit board:

low calibration point:

1. Insert the sensor probe into the reference humidity 1 (low calibration point) and stabilise for at least 20 minutes.

2. BUTTON S2:

Pressing the button for 5 seconds starts the procedure for the calibration mode RH. The calibration mode is indicated by the lit LED "D2" on the circuit board.

3. BUTTON S2:

Pressing the button for 5 seconds starts the procedure for the low calibration point. The calibration mode is indicated by the lit LED "D2" and the symbol "CALIB LOW" will appear on the optional LC display.

4. BUTTON S1 (up) and S2 (down):

Pressing one of the two buttons will adjust the measuring value in steps of 0.1% up or down to the reference value. The actual measuring value is indicated on the display or can be measured with the analogue output. As soon as the measured value is changed, "D1" flashes resp. disappears when pressing alternating S1 resp. S2.

5. **BUTTON S1 (store):**

Pressing the button for 5 seconds stores the calibration value and the procedure is ended. LED "D2" flashes to indicate exiting of the calibration mode and the symbol "CALIB LOW" will disappear from the optional LC display.

BUTTON S2 (cancel):

Pressing the button for 5 seconds the calibration procedure will be ended without storing the calibration values. LED "D2" flashes to indicate exiting of the calibration mode and the symbol "CALIB LOW" will disappear from the optional LC display.

high calibration point:

6. Insert the sensor probe into the reference humidity 2 (high calibration point) and stabilise for at least 20 minutes.

7. **BUTTON S2:**

Pressing the button for 5 seconds starts the procedure for the calibration mode RH. The calibration mode is indicated by the lit LED "D2" on the circuit board.

8. **BUTTON S1:**

Pressing the button for 5 seconds starts the procedure for the high calibration point. The calibration mode is indicated by the lit LED "D2" and the symbol "CALIB HIGH" will appear on the optional LC display.

9. **BUTTON S1 (up) and S2 (down):**

Pressing one of the two buttons will adjust the measuring value in steps of 0.1% up or down to the reference value. The actual measuring value is indicated on the display or can be measured with the analogue output. As soon as the measured value is changed, "D1" flashes resp. disappears when pressing alternating S1 resp. S2.

10. **BUTTON S1 (store):**

Pressing the button for 5 seconds stores the calibration value and the procedure is ended. LED "D2" flashes to indicate exiting of the calibration mode and the symbol "CALIB HIGH" will disappear from the optional LC display.

BUTTON S2 (cancel):

Pressing the button for 5 seconds the calibration procedure will be ended without storing the calibration values. LED "D2" flashes to indicate exiting of the calibration mode and the symbol "CALIB HIGH" will disappear from the optional LC display.

7.2 2-point temperature calibration



- Start calibration at the low calibration point!
- The temperature difference between the two points should be at least 30 degC (86°F)!
- Low temperature point < high temperature point
- Attention: A 2-point temperature calibration is not supported by the configuration software and must therefore be done directly on the circuit board! (see the following procedure)

7.2.1 2-point temperature calibration procedure on the circuit board:

low calibration point:

1. Insert the sensor probe into the reference temperature 1 (low calibration point) and stabilise for at least 20 minutes.

2. BUTTON S1:

Pressing the button for 5 seconds starts the procedure for the calibration mode temperature. The calibration mode is indicated by the lit LED "D1" on the circuit board.

3. BUTTON S2:

Pressing the button for 5 seconds starts the procedure for the low calibration point. The calibration mode is indicated by the symbol "CALIB LOW" on the optional LC display.

4. BUTTON S1 (up) and S2 (down):

Pressing one of the two buttons will adjust the measuring value in steps of 0.1 degC up or down to the reference value. The actual measuring value is indicated on the display or can be measured with the analogue output. As soon as the measured value is changed, "D1" flashes resp. disappears when pressing alternating S1 resp. S2.

5. BUTTON S1 (store):

Pressing the button for 5 seconds stores the calibration value and the procedure is ended. LED "D2" flashes to indicate exiting of the calibration mode and the symbol "CALIB LOW" will disappear from the optional LC display.

BUTTON S2 (cancel):

Pressing the button for 5 seconds the calibration procedure will be ended without storing the calibration values. LED "D2" flashes to indicate exiting of the calibration mode and the symbol "CALIB LOW" will disappear from the optional LC display.

high calibration point:

6. Insert the sensor probe into the reference temperature 2 (high calibration point) and stabilise for at least 20 minutes.

7. BUTTON S1:

Pressing the button for 5 seconds starts the procedure for the calibration mode temperature. The calibration mode is indicated by the lit LED "D1" on the circuit board.

8. BUTTON S1:

Pressing the button for 5 seconds starts the procedure for the high calibration point. The calibration mode is indicated by the symbol "CALIB HIGH" on the optional LC display.

9. BUTTON S1 (up) and S2 (down):

Pressing one of the two buttons will adjust the measuring value in steps of 0.1 degC up or down to the reference value. The actual measuring value is indicated on the display or can be measured with the analogue output. As soon as the measured value is changed, "D1" flashes resp. disappears when pressing alternating S1 resp. S2.

10. BUTTON S1 (store):

Pressing the button for 5 seconds stores the calibration value and the procedure is ended. LED "D2" flashes to indicate exiting of the calibration mode and the symbol "CALIB HIGH" will disappear from the optional LC display.

BUTTON S2 (cancel):

Pressing the button for 5 seconds the calibration procedure will be ended without storing the calibration values. LED "D2" flashes to indicate exiting of the calibration mode and the symbol "CALIB HIGH" will disappear from the optional LC display.

7.3 1-point humidity calibration

When the working range is limited to a certain more narrow range, a calibration at one humidity point is sufficient.

- In accordance with the working range, either the high or low calibration point should be selected. (CP > or < 50% RH)



- This calibration causes an extra inaccuracy for the rest of the working range.
- The 1-point humidity calibration may be done directly on the circuit board or using the configuration software supplied. (for more details, see the Configuration Software, chapter 5.4 "1-point humidity calibration")

7.3.1 1-point humidity calibration procedure on the circuit board:

1. Insert the sensor probe into the reference humidity (calibration point) and stabilise for at least 20 minutes.

2. BUTTON S2:

Pressing the button for 5 seconds starts the procedure for the calibration mode RH. The calibration mode is indicated by the lit LED "D2" on the circuit board.

3. BUTTON S1:

Pressing the button for 5 seconds starts the procedure. The calibration mode is indicated by the lit LED "D2" and the symbol "CALIB HIGH" will appear on the optional LC display (CP ≥ 50% RH).

or

BUTTON S2:

Pressing the button for 5 seconds starts the procedure. The calibration mode is indicated by the lit LED "D2" and the symbol "CALIB LOW" will appear on the optional LCD (CP < 50% RH).

4. BUTTON S1 (up) and S2 (down):

Pressing one of the two buttons will adjust the measuring value in steps of 0.1% up or down to the reference value. The actual measuring value is indicated on the display or can be measured with the analogue output.

5. BUTTON S1 (store):

Pressing the button for 5 seconds stores the calibration value and the procedure is ended. LED "D2" flashes to indicate exiting of the calibration mode and the symbol "CALIB LOW" or "CALIB HIGH" will disappear from the optional LC display.

BUTTON S2 (cancel):

Pressing the button for 5 seconds the calibration procedure will be ended without storing the calibration values. LED "D2" flashes to indicate exiting of the calibration mode and the symbol "CALIB LOW" or "CALIB HIGH" will disappear from the optional LC display.

7.4 1-point temperature calibration

When the working range is limited to a certain more narrow range, a calibration at one temperature point is sufficient.

- In accordance with the working range, either the high or low calibration point should be selected. (CP \geq or $<$ 45 degC / 113°F)



- This calibration causes an extra inaccuracy for the rest of the working range.
- The 1-point temperature calibration may be performed directly on the circuit board or using the configuration software supplied. (for more details, see Configuration Software, chapter 5.4 "1-point temperature calibration")

7.4.1 1-point temperature calibration procedure on the circuit board:

1. Insert the sensor probe into the reference temperature (calibration point) and stabilise for at least 20 minutes.

2. BUTTON S1:

Pressing the button for 5 seconds starts the procedure for the calibration mode temperature. The calibration mode is indicated by the lit LED "D1" on the circuit board

3. BUTTON S1:

Pressing the button for 5 seconds starts the procedure. The calibration mode is indicated by the symbol "CALIB HIGH" on the optional LC display (CP \geq 45 degC / 113°F).

or

BUTTON S2:

Pressing the button for 5 seconds starts the procedure. The calibration mode is indicated by the symbol "CALIB LOW" on the optional LC display (CP $<$ 45 degC / 113°F).

4. BUTTON S1 (up) and S2 (down):

Pressing one of the two buttons will adjust the measuring value in steps of 0.1 degC up or down to the reference value. The actual measuring value is indicated on the display or can be measured with the analogue output.

5. BUTTON S1 (store):

Pressing the button for 5 seconds stores the calibration value and the procedure is ended. LED "D2" flashes to indicate exiting of the calibration mode and the symbol "CALIB LOW" or "CALIB HIGH" will disappear from the optional LC display.

BUTTON S2 (cancel):

Pressing the button for 5 seconds the calibration procedure will be ended without storing the calibration values. LED "D2" flashes to indicate exiting of the calibration mode and the symbol "CALIB LOW" or "CALIB HIGH" will disappear from the optional LC display.

7.5 Return to factory calibration

1. RH + T RESET: BUTTON S1 and S2:

In neutral mode pressing buttons S1 and S2 simultaneously for 10 seconds customer calibration settings are reset to factory calibration. A short flash of the LED "D1" indicates the reset.

or

2. RH RESET: BUTTON S2:

Pressing the button for 5 seconds starts the procedure for the calibration mode RH. Pressing buttons S1 and S2 simultaneously for 10 seconds customer calibration settings are reset to factory calibration. A short flash of the LED "D1" indicates the reset.

or

3. Temp. RESET: BUTTON S1:

Pressing the button for 5 seconds starts the procedure for the calibration mode T. Pressing buttons S1 and S2 simultaneously for 10 seconds customer calibration settings are reset to factory calibration. A short flash of the LED "D2" indicates the reset.

8 MAINTENANCE

8.1 Sensor cleaning

Cleaning of humidity and temperature sensors from oil residue:

- 1) Remove filter cap carefully, do not touch the sensors
- 2) Immerse the measuring head in N-HEPTAN and swirl for approx. 30 seconds
- 3) Rinse with tap water and allow to air dry for approx. 30 minutes
- 4) Screw on filter cap carefully

Cleaning of the measuring head is recommended before emerging in other oil and before a calibration.

8.2 Sensor replacement

Under certain circumstances, the capacitive humidity sensor element can get damaged. To avoid the costly return of the entire transmitter to the manufacturer it is possible to replace the sensor.



Note:

- This will invalidate the factory calibration.
- The sensor elements may be touched at the lead wires only. (use tweezers!)

8.2.1 Sensor replacement of pluggable sensors

1. Switch off supply voltage.
2. Loosen the fixing of the filter cap with an appropriate tool (see pic.1).
3. Unscrew the filter cap carefully.
4. Pull out the humidity sensor element.
5. Put in the new humidity sensor, the active side has to face the inside (see pic.2).
6. Screw the filter cap on again (in case of pollution replace it by a new filter cap).
7. Press in the fixing of the filter cap.
8. Establish connection to PC (RS232).
9. Switch on the supply voltage.
10. Start configuration software on PC.
11. For further instructions, see Configuration software, chapter 5.3 "Sensor/Probe replacement".

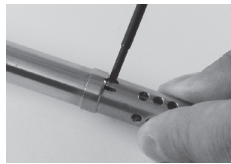

pic.1: loosen the fixing

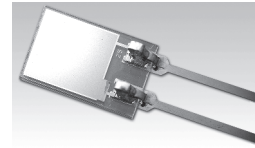
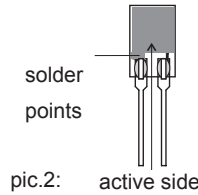

8.2.2 Sensor replacement of soldered sensors

1. Switch off supply voltage.
2. Loosen the fixing of the filter cap with an appropriate tool (see pic.1).
3. Unscrew the filter cap carefully.
4. Desolder the humidity sensor element.
5. Shorten the sensor legs of the replacement sensor with a side cutter at 4mm (0.16") (from 10mm / 0.39" to 6mm / 0.24"), see pic.2.
6. Solder in the new humidity sensor, the active side has to face the inside (see pic.2)
7. Screw the filter cap on again (in case of pollution replace it by a new filter cap).
8. Press in the fixing of the filter cap.
9. Establish connection to PC (RS232).
10. Switch on the supply voltage.
11. Start configuration software on PC.
12. For further instructions, see Configuration software, chapter 5.3 "Sensor/Probe replacement".

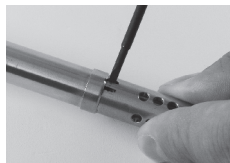

pic.1: loosen the fixing

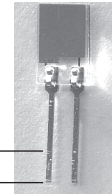
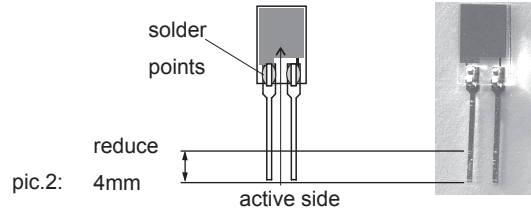

8.3 Probe replacement

Transmitters of the EE36 series are available with an optional remote sensor probe that can be plugged into the middle section of the housing. If the sensor probe is damaged (damage to the cable, mechanical destruction of the sensor probe) it is possible to replace the probe.



Note:

This will invalidate the factory calibration.

8.3.1 Probe replacement procedure:

1. Switch off supply voltage.
2. Remove damaged sensor probe.
3. Plug replacement probe onto middle section of the housing.
4. Establish connection to PC (RS232).
5. Switch on power supply voltage.
6. Start configuration software on PC.
7. For further instructions, see Configuration software, chapter 5.3 "Sensor/Probe replacement"

8.4 Self diagnostics and error messages

8.4.1 Self diagnostics via LEDs on the circuit board:

Green LED

flashing → Supply voltage applied / Microprocessor is active

Red LED

constantly lit → Humidity sensor element damaged

flashing → Short circuit at sensor / free water in oil

8.4.2 Self diagnostics via display (where available):

Error 1 → Humidity sensor element damaged

Error 2 → Humidity sensor element moistened (condensation!)

Error 3 → Temperature sensor element damaged

Error 4 → Temperature input short circuit

8.4.3 Definitions:



Error

- possible cause → Measures / Help

Display shows incorrect values

- Error during re-adjustment of the sensor → Reset to factory calibration and repeat the calibration
- Filter soiled → Replace filter
- Sensor defective → Replace sensor
- Output configured incorrectly → PC - Software

Transmitter failure

- no supply voltage → Check wiring and supply voltage
- only green LED is illuminated continuously → Electronics defect, contact the manufacturer

8.5 Replacement of sealing element

Because of repeated installations and various other circumstances the sealing element can get damaged. The customer can do a replacement of this sealing element (refer to drawing).

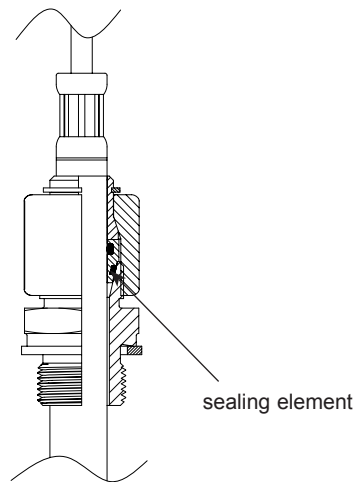

9 SCOPE OF SUPPLY

	Included in all versions	According to ordering guide
EE36 according to ordering guide	x	
Manual EE36 German/English/French	x	
EE-PCA configuration software	x	
Inspection certificate according to DIN EN 10204	x	
Allen key 3.0	x	
Mating plug for integrated power supply		V01
Mating plug RKC 5/7		V01 / C03 / C07
Mating plug RSC 5/7		C06 / C07
M16 cable gland metal		except C03, C06, C07, V01

10 REPLACEMENT PARTS / ACCESSORIES

• Display + housing cover	D05M
• Interface cable for PCB	HA010304
• Replacement probe	PExxxx*
• Interface cable for plug C06, C07	HA010311
• Humidity sensor	FE09
• Ball valve set 1/2" ISO	HA050101
• Calibration set	HA0104xx
• Ball valve set 1/2" NPT	HA050104
• Sealing element	HA050308
• Double nibble G1/2" to G3/4"	HA011107
• Stainless steel filter for EE36	HA010110
• Enlargement G1/2" to G3/4"	HA011106

* Only for Version P01 available

11 TECHNICAL DATA

Measuring values

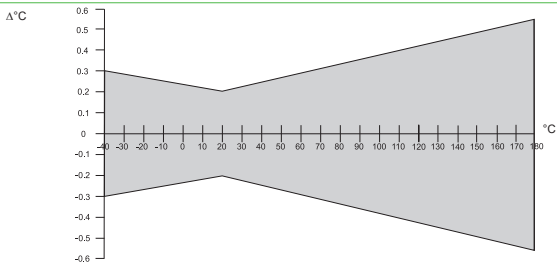
Water activity	
Measuring range ¹⁾	0...1 a _w
Accuracy ²⁾ (including hysteresis, non-linearity and repeatability, traceable to intern. standards, administrated by NIST, PTB, BEV...)	
-15...40 °C (5...104 °F)	≤0.9 a _w ± (0.013 + 0.3%*mv) a _w
-15...40 °C (5...104 °F)	>0.9 a _w ± 0.023 a _w
-25...70 °C (-13...158 °F)	± (0.014 + 1%*mv) a _w
-40...180 °C (-40...356 °F)	± (0.015 + 1.5%*mv) a _w
Temperature dependence	
of electronics	typ. ± 0.0001 [1/°C] (typ. ± 5.6 * 10 ⁻⁵ [1/°F])
of sensing probe	typ. ± (0.00002 + 0.0002 x aw) x ΔT [°C] ΔT = T - 20 °C
Response time with stainless steel filter at 20 °C (68 °F) / t ₉₀	
	typ. 10 min in still oil
Temperature	
Temperatur sensor element	Pt1000 (tolerance class A, DIN EN 60751)
Working range sensing probe	-40...180 °C (-40...356 °F)
Accuracy	
Temperature dependence of electronics	typ. ± 0.005 °C/°C

Outputs²⁾

Two freely selectable and scaleable analogue outputs	0 - 5 V	-1 mA < I _L < 1 mA
	0 - 10 V	-1 mA < I _L < 1 mA
	4 - 20 mA	R _L < 500 Ohm
	0 - 20 mA	R _L < 500 Ohm

Adjustable measurement range²⁾

		from	up to	units
Water activity	a _w	0	1	
Temperature	T	-40 (-40)	180 (356)	°C (°F)
Water content ³⁾	x	0	100 000	ppm

General

Supply voltage	8...35 V DC 12...30 V AC (optional 100...240 V AC, 50/60 Hz)	
Current consumption	- 2x voltage output - 2x current output	for 24V DC/AC: typ. 40 mA typ. 80 mA
Pressure range sensing probe	0.01...20 bar (0.15...300 psi)	
System requirements for software	WINDOWS 2000 or later; serial interface	
Serial interface for configuration ⁴⁾	RS232C	
Housing / Protection class	Al Si 9 Cu 3 / IP65 / NEMA 4	
Cable gland	M16 x 1.5 cable Ø 4.5 - 10 mm (0.18 - 0.39")	
Electrical connection	screw terminals up to max. 1.5 mm ² (AWG 16)	
Sensor protection	stainless steel filter	
Operating temperature range of electronics	-40...60 °C (-40...140 °F)	
Working and storage temperature range		
Housing with display	-20...50 °C (-4...122 °F)	
Storage temperature	-40...60 °C (-40...140 °F)	
Electromagnetic compatibility according to	EN61326-1 Industrial Environment	EN61326-2-3 ICES-003 ClassB FCC Part15 ClassB
DNV GL-Certification ⁵⁾	Environmental Category D	



Options

Display	graphical LCD (128x32 pixels), with integrated push-buttons for selecting parameters and MIN/MAX function	
Alarm outputs	2 x 1 switch contact: 250 V AC / 6 A and 28 V DC / 6 A threshold + hysteresis can be adjusted with configuration software	
Switching parameters (freely selectable)	aw	Water activity
	T	Temperature
	x	Water content

1) refer to the working range of the humidity sensor. 2) can be easily changed by software 3) ppm output is valid in the range 0...100°C (32...212°F) 4) no data output
*) The accuracy statement includes the uncertainty of the factory calibration with an enhancement factor k=2 (2-times standard deviation). The accuracy was calculated in accordance with EA-4/02 and with regard to GUM (Guide to the Expression of Uncertainty in Measurement).



HEADQUARTERS

E+E ELEKTRONIK Ges.m.b.H.

Langwiesen 7
A-4209 Engerwitzdorf
Austria
Tel: +43 7235 605 0
Fax: +43 7235 605 8
info@epluse.com
www.epluse.com

SUBSIDIARIES

E+E Elektronik Germany

info@epluse.de

Office Bad Homburg
Tel: +49 6172 13881 0

Office Hamburg
Tel: +49 160 9050 6460

Office Stuttgart
Tel: +49 151 5383 7500

E+E Elektronik Italy

Tel: +39 02 2707 8636
info@epluse.it

E+E Elektronik France

Tel: +33 4 7472 35 82
info@epluse.fr

E+E Elektronik Korea

Tel: +82 31 732 6050
info@epluse.co.kr

E+E Elektronik USA

info@epluse.de

Office Chicago
Tel: +1 847 490 7813

Office Boston
Tel: +1 508 530 3068

E+E Elektronik China

info@epluse.cn

Office Beijing
Tel: +86 10 8499 2361

Office Shanghai
Tel: +86 21 6117 6129

Office Guangzhou
Tel: +86 20 3898 7052

YOUR PARTNER IN SENSOR TECHNOLOGY



ELEKTRONIK®
Ges.m.b.H.