



—
your partner
in sensor
technology.

+ User Manual EE371

Compact Dew Point Sensor



Content

1	General Information	3
1.1	Explanation of Warning Notices and Symbols	3
1.2	Safety Instructions	4
1.2.1	General Safety Instructions	4
1.2.2	Intended Use	4
1.2.3	Mounting, Start-up and Operation	4
1.3	Environmental Aspects	5
2	Scope of Supply	5
3	Product Description	6
3.1	General	6
3.2	Dimensions	6
3.3	Electrical Connection	7
3.4	Auto-Calibration	7
3.5	Measuring Range and Accuracy	8
4	Mounting and Installation	8
4.1	Installation Location	8
4.2	Installing Directly into the Process	9
4.3	Mounting with a Sampling Cell	9
4.3.1	Basic Sampling Cell	10
4.3.2	Sampling Cell with Quick Connector	11
5	Operating Components	11
5.1	Electronics Board	11
5.2	Display module (Option)	12
6	Setup and Adjustment	13
6.1	PCS10 Product Configuration Software	13
7	Maintenance and Service	13
7.1	Calibration and Adjustment	13
7.2	Dew Point Adjustment	13
7.3	Filter Cap Exchange	14
7.4	Cleaning the Sensing Element	14
7.5	Self-Diagnosis and Error Messages	14
7.6	Repairs	14
8	Accessories	15
9	Technical Data	15
10	Conformity	17
10.1	Declarations of Conformity	17
10.2	Electromagnetic Compatibility	17
10.3	FCC Part 15 Compliance Statement	17
10.4	ICES-003 Compliance Statement	17

1 General Information

This user manual is intended to ensure proper handling and optimal functioning of the device. The user manual shall be read before commissioning the equipment and it shall be provided to all staff involved in transport, installation, operation, maintenance and repair. E+E Elektronik Ges.m.b.H. accepts no liability for any warranty or liability claims arising from this publication or improper handling of the product(s) described.

All information, technical data and diagrams included in this document are based on the information available at the time of writing. The document may contain technical inaccuracies and typographical errors. The contents will be revised on a regular basis and changes will be implemented in subsequent versions. The product(s) described and the contents of this document may be changed or improved at any time without prior notice.

All rights are reserved by E+E Elektronik Ges.m.b.H. No part of this document may be reproduced, published or publicly displayed in any form or by any means, nor may its contents be modified, translated, adapted, sold or disclosed to a third party without prior written permission of E+E Elektronik Ges.m.b.H.

PLEASE NOTE

Find this document and further product information on our website at www.epluse.com/ee371.

1.1 Explanation of Warning Notices and Symbols

Safety precautions

Precautionary statements warn of hazards in handling the device and provide information on their prevention. The safety instruction labeling is classified by hazard severity and is divided into the following groups:

DANGER

Danger indicates hazards for persons. If the safety instruction marked in this way is not followed, the hazard will very likely result in severe injury or death.

WARNING

Warning indicates hazards for persons. If the safety instruction marked in this way is not followed, there is a risk of injury or death.

CAUTION

Caution indicates hazards for persons. If the safety instruction marked in this way is not followed, minor or moderate injuries may occur.

NOTICE

Notice signals danger to objects or data. If the notice is not observed, damage to property or data may occur.

Informative notes

Informative notes provide important information that is characterised by its relevance.

INFO

The information symbol indicates tips on handling the device or provides additional information on it. This information is useful to achieve optimum performance of the device.

The title field may deviate from "INFO" depending on the context. For instance, it may also read "PLEASE NOTE".

1.2 Safety Instructions

1.2.1 General Safety Instructions

NOTICE

Improper handling of the device may result in its damage.

- The EE371 enclosure, the sensing probe and the sensing module shall not be exposed to unnecessary mechanical stress.
- Use the EE371 only as intended and observe all technical specifications.

1.2.2 Intended Use

The EE371 is intended for the dew point temperature (Td) measurement of compressed air and other non-corrosive and non-flammable gases at pressures. The sensor can be installed in a pressurised system up to 20 bar (300 psi) and 100 bar (1 450 psi), respectively.

WARNING

Non-compliance with the product documentation may cause safety risks for people and the entire measurement installation.

The manufacturer is not liable for any damage caused by improper handling, installation and maintenance of the device.

- Do not use the EE371 in explosive atmosphere or for measurement in aggressive gases.
- This device is not appropriate for safety, emergency stop or other critical applications where device malfunction or failure could cause injury to human beings.
- The device may not be manipulated with tools other than specifically described in this manual.

NOTICE

Failure to follow the instructions in this user manual may lead to measurement inaccuracy and device failures.

- The EE371 may only be operated under the conditions described in this user manual and within the specification included in chapter 9 Technical Data.
- Any unauthorised product modifications will invalidate all warranty claims. Modifications may only be carried out with express authorisation of E+E Elektronik Ges.m.b.H.!

1.2.3 Mounting, Start-up and Operation

The EE371 has been produced under state of the art manufacturing conditions, has been thoroughly tested and has left the factory after fulfilling all safety criteria. The manufacturer has taken all precautions to ensure safe operation of the device. The device shall be set up and installed in a way that does not impair its safe use. All applicable local and international safety guidelines for safe installation and operation of the device have to be observed. This user manual contains information and warnings that must be observed in order to ensure safe operation.

PLEASE NOTE

The manufacturer or his authorised agent can only be held liable in case of willful or gross negligence. In any case, the scope of liability is limited to the corresponding amount of the order issued to the manufacturer. The manufacturer assumes no liability for damage caused by non-compliance with the applicable regulations, operating instructions or the specified operating conditions. Any consequential damage is excluded from liability.

⚠ WARNING

Non-compliance with the product documentation may cause accidents, personal injury or property damage.

- Mounting, installation, commissioning, start-up, operation and maintenance of the device may only be carried out by qualified staff. Such staff must be authorised by the operator of the facility to carry out the mentioned activities.
- The qualified staff must have read and understood this user manual and must follow the instructions contained within. The manufacturer accepts no responsibility for non-compliance with instructions, recommendations and warnings.
- All process and electrical connections must be thoroughly checked by authorised staff before commissioning the device.
- Do not install or start-up a device suspected to be faulty. Mark it clearly as faulty and remove it from the process.
- Service operations other than described in this user manual may only be performed by the manufacturer. A faulty device may only be investigated and possibly repaired by qualified, trained and authorised staff. If the fault cannot be fixed, the device shall be removed from the process.

1.3 Environmental Aspects

i PLEASE NOTE

Products from E+E Elektronik Ges.m.b.H. are developed and manufactured in compliance with relevant environmental protection requirements. Please observe local regulations for the disposal of the device.



For disposal, the individual components of the device must be separated according to local recycling regulations. The electronics shall be disposed of correctly as electronics waste.

2 Scope of Supply

- EE371 – Compact Dew Point Sensor
- Inspection certificate according to DIN EN 10204-3.1
- Quick guide

3 Product Description

3.1 General

The compact EE371 Dew Point Sensor with a measuring range down to -60 °C (-76 °F) Td and a robust stainless steel enclosure is ideal for OEM applications in compressed air systems, plastic dryers and industrial drying processes. The core of the EE371 is the monolithic measurement cell type HMC200, manufactured in thin-film technology.

Thanks to its excellent long-term stability and durability against condensation, the EE371 requires minimal maintenance.

An integrated auto-calibration procedure enables measurements to be taken with an accuracy of $\pm 2\text{ °C}$ Td ($\pm 3.6\text{ °F}$) Td. The recommended calibration interval is two years.

Measured values for dew point, frost point or volume concentration are available on two analogue outputs with $4 - 20\text{ mA}$ or $0 - 10\text{ V}$.

3.2 Dimensions

Values in mm (inch)

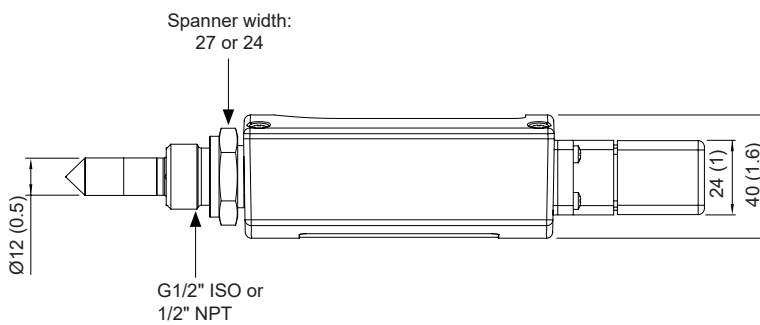
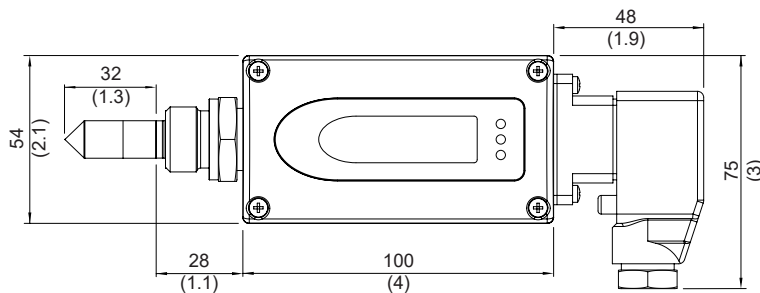

3.3 Electrical Connection

⚠ WARNING

Incorrect installation, wiring or power supply may cause overheating and result in personal injury or property damage.

For correct cabling, always observe the presented wiring diagram for the product version used.

The manufacturer cannot be held responsible for personal injury or damage to property caused by incorrect handling, installation, wiring, power supply or maintenance of the device.

The electrical connection is made via the 7-pin connector DIN VDE 0627 / IEC 61984. A mating connector is included in scope of supply.

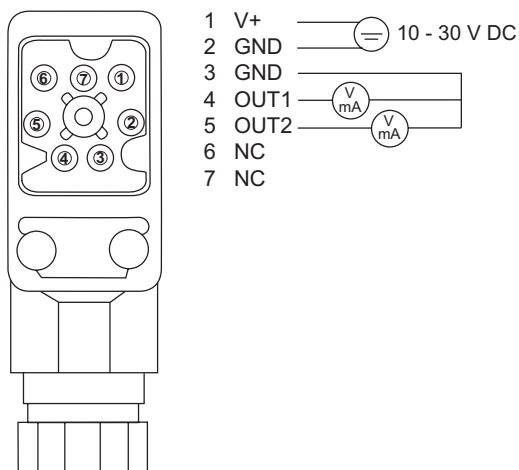

Fig. 1 Analogue output

3.4 Auto-Calibration

At room temperature, dew point temperatures ranging from $-60\dots-20\text{ °C}$ ($-76\dots-4\text{ °F}$) correspond to relative humidities of between 0.08 % and 5.37 %RH.

To ensure accuracy at the lowest humidity level, even the smallest drift effects in the humidity sensing element must be compensated for.

A special auto-calibration method compensates for the usual drift effects, resulting in highly accurate measurements even at the lowest dew point temperatures.

Auto-calibration is carried out every 30 minutes and takes approx. 3 minutes.

After a longer period of inactivity, restarting the device may require a time-consuming auto-calibration process until the device is back within the specified parameters. Therefore, an extended auto-calibration takes place 5 minutes after power-on. This takes slightly longer than the normal calibration and is performed up to five times in the first hour of operation.

During auto-calibration, the analogue output switches to the “Frozen output signal” state, where the last measured value is stored (standard behaviour).

3.5 Measuring Range and Accuracy

The EE371 has an accuracy of ± 2 °C specified within a measuring range of -60...+60 °C dew point.

Measuring signal limitation:

at medium temperature ≤ 20 °C (≤ 68 °F): Td limitation = -80 °C (-112 °F)

at medium temperature > 20 °C (> 68 °F): Td limitation = medium temperature -100 °C (-148 °F)

e.g. at medium temperature 40 °C (104 °F) the measuring signal is limited at -60 °C (-76 °F) dew point.

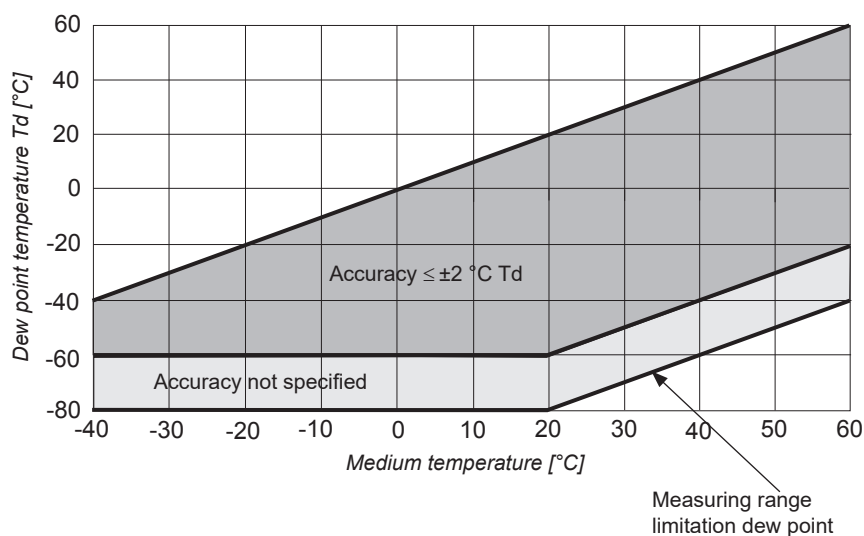

Fig. 2 Dew point measuring range and specified accuracy

The maximum scaling of the analogue output is -100...+80 °C (-148...+176 °F) dew point.

4 Mounting and Installation

4.1 Installation Location

Select a location that offers optimum measuring conditions. Air must be able to circulate freely around the sensing element. Temperature differences between the process and the location of installation do not affect the dew point measurement. However, be aware that changes in the pressure of a gas also changes the dew point. A pressure difference between the installation location and the process can cause a measurement several tens of degrees dew point off. The exact effects of changes in pressure on the dew point can be simulated using the E+E humidity calculator. Please find further details on our website www.epluse.com.

Avoid leakages, otherwise the ingress of moisture from the environment will interfere with the measurement.

i PLEASE NOTE

On delivery, the sensor is protected by a cap that keeps the dew point sensor dry. The cap should only be removed right before installation in the application.

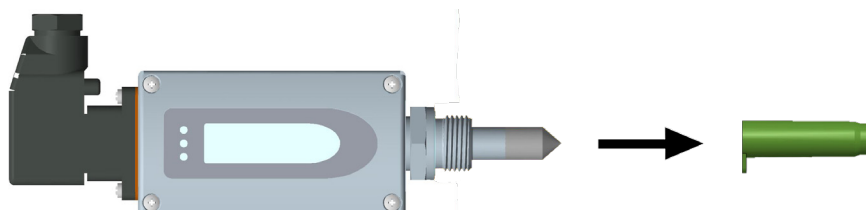

Fig. 3 Remove the protection cap

4.2 Installing Directly into the Process

For direct installation in the pipeline, install a shut-off valve on both sides of the process. The sensor can therefore be easily removed for maintenance and calibration work.

i PLEASE NOTE

It is not permitted to use a sealing ring with a NPT 1/2" thread. Use an appropriate PTFE sealing tape or sealant instead.

Insert the sensor into the process and tighten it by hand as far as possible. If available, check the sealing ring for correct centring. Tighten the screw connection to a defined torque of 30 Nm.

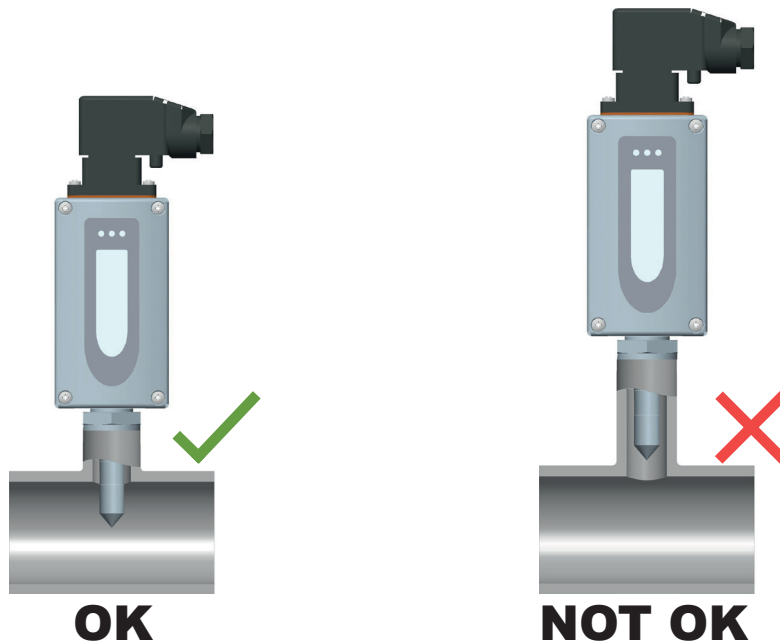

Fig. 4 Direct mounting to the pipe

4.3 Mounting with a Sampling Cell

Sampling is necessary if a direct installation of the sensor in the process is not possible or not required.

Reasons may be:

- Process temperature is too high
- Sensor shall be protected against contamination.
- Removing the sensor must not interrupt the process.

i PLEASE NOTE

To obtain a representative sample of process gas and to avoid measuring errors, please not the following:

- Differences in pressure between the process and the sampling chamber will result in significant measuring errors.
- Measurements taken at low dew point temperatures are sensitive to humidity diffusing from the environment due to leaks. Therefore, the sampling system must be pressure-tight.
- Use non-hygroscopic materials.
- The sampling line must be kept as short as possible.
- The response time increases if the gas flow is <math>< 1 \text{ l/min}</math> (0.25 gpm).
- A too low gas flow can result in back-diffusion of humidity from the environment and distort the measurement.

The pipe material has a significant influence on the response time and the lowest achievable dew point temperature. Fig. 5 illustrates how different tubing materials give off moisture over time when flushed with very dry gas after being at ambient humidity.

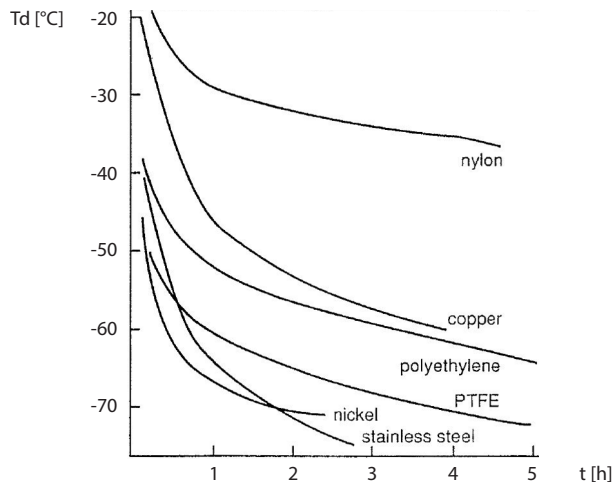

Fig. 5 Moisture given off by different tubing materials (© National Physical Laboratory)

These several sampling cells are optionally available

- Basic sampling cell
- Sampling cell with quick connector and bleed screw
- Sampling cell for atmospheric dew point

Please refer to EE371 datasheet and to chapter 8 Accessories of this document.

4.3.1 Basic Sampling Cell

Pressure range: 0...64 bar (0...930 psi)

Order code HA050103 (ISO) HA050105 (NPT)

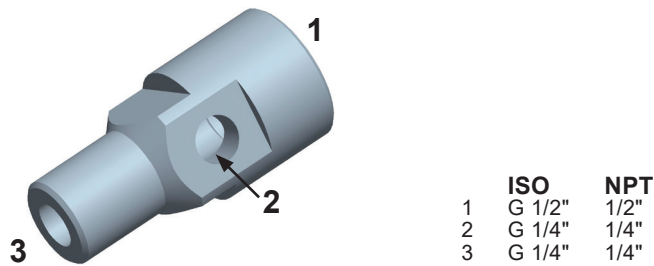

Fig. 6 Basic sampling cell

4.3.2 Sampling Cell with Quick Connector

The sampling cell features a quick-connector suitable for standard compressed air connections DN7.2. It allows the cell to be installed and removed without process interruption. The air (gas) flow along the sensing head of EE371 can be adjusted using the bleed screw.

Pressure range: 0...10 bar (0...150 psi)

Order code: HA050102

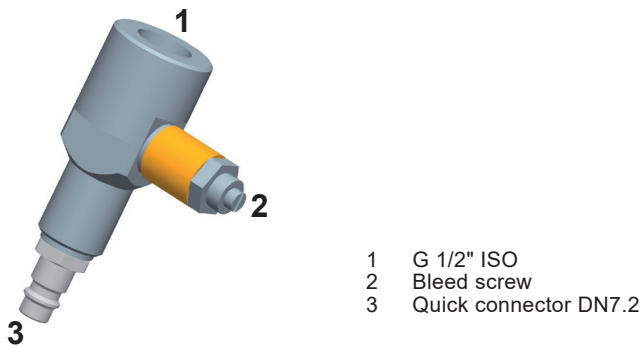

- 1 G 1/2" ISO
- 2 Bleed screw
- 3 Quick connector DN7.2

Fig. 7 Sampling cell with quick connector

5 Operating Components

5.1 Electronics Board

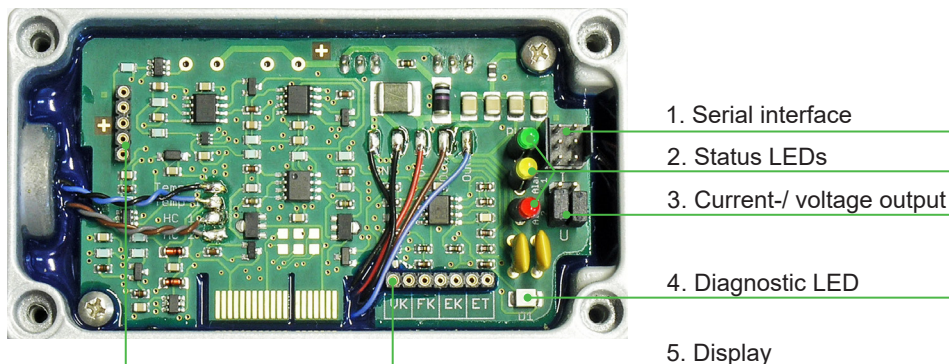

Serial interface:

Connector for serial interface cable HA010304 or EE-PCA Product Configuration Adapter with HA011063. See data sheets EE371, Accessories and EE-PCA at www.epluse.com/ee371.

Status LEDs:

Provide information on the status of the EE371.



Green (Power LED): flashing = EE371 is correctly powered.
The yellow and red LEDs don't have a function.

Current-/ voltage output:

Jumpers are provided to select the analogue output signal. Switching from voltage to current or vice versa should be carried out both via the hardware (jumpers) and via the software (with the PCS10 Product Configuration Software).

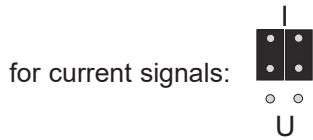

Diagnostic LED:

Error Indication. See chapter 7.5 Self-Diagnosis and Error Messages.

Display:

Connectors for the optional display module.

5.2 Display module (Option)

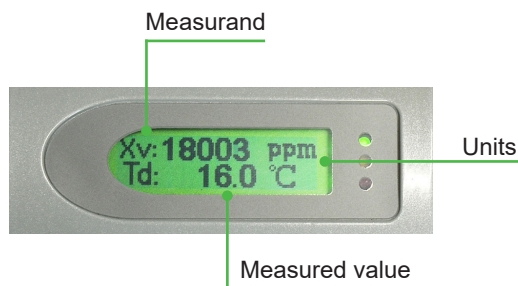

Measurand	Units	
	SI	US
Td dew point temperature	°C	°F
Tf frost point temperature	°C	°F
Wv volume concentration	ppm	ppm

Measured value	
Td	-60...+60 °C Td (-112...+140 °F Td)
Tf	-60...0 °C Tf* (-112...+32 °F Tf)
Wv	20...200 000 ppm

*) Above 0 °C medium temperature, Td will be displayed

6 Setup and Adjustment

The EE371 sensor is ready to use and does not require any further configuration. The factory setup corresponds to the specified order code. Please refer to the data sheet at www.epluse.com/ee371.

If required, the factory configuration can be modified. This chapter details the available configuration methods using the free PCS10 Product Configuration Software, either in conjunction with the optional RS232 interface cable (order code HA010304) or with the EE-PCA Product Configuration Adapter and the corresponding connection cable (order code HA011063).

The software supports sensor adjustment, calibration, and modification of analogue output scaling.

6.1 PCS10 Product Configuration Software

The PCS10 provides a convenient graphical user interface for the EE371 to modify the factory setup.

Use the software to change the settings and proceed as follows:

1. Download the PCS10 Product Configuration Software from www.epluse.com/pcs10 and install it on a PC.
2. Connect the EE371 to the PC using one of the following methods:
 - Connection via EE-PCA:**
PC (USB/RS232) → EE-PCA Product Configuration Adapter → HA01163 connection cable → EE371 (with external power supply)
 - Direct RS232 connection (optional):**
PC (RS232 port) → HA010304 RS232 interface cable → EE371 (with external power supply).
3. Start the PCS10 software.
4. Follow the instructions on the PCS10 opening page to scan the ports and to identify the connected device.
5. Click on the desired setup or adjustment mode from the main PCS10 menu on the left. Follow the PCS10 online instructions that are displayed when clicking on the "Tutorial" button.
6. Upload changes to the sensor by pressing the "Sync" button.

7 Maintenance and Service

7.1 Calibration and Adjustment

Definitions

- **Calibration** documents the accuracy of a measurement device. The device under test (specimen) is compared with the reference and the deviations are documented in a calibration certificate. During the calibration, the specimen is not changed or improved in any way.
- **Adjustment** improves the measurement accuracy of a device. The specimen is compared with the reference and brought in line with it. An adjustment can be followed by a calibration which documents the accuracy of the adjusted specimen.

The dew point temperature adjustment of EE371 can be performed with the free EE-PCS Product Configuration Software, free download at www.epluse.com/configurator.

7.2 Dew Point Adjustment

User-performed dew point adjustment is only possible at low dew points. The adjustment may be carried out when the difference between the ambient temperature and the reference dew point temperature is less than -60 °C (-76 °F).

Example:

Ambient temperature: +20 °C (+68°F)

Required reference dew point temperature: below -40 °C (-40° F).

7.3 Filter Cap Exchange

In a dusty, polluted environment it might be necessary to replace the filter cap occasionally. In most cases, visible contamination or dirt indicate a clogged filter. Longer response time of the measurement also indicates a clogged filter cap. In this cases, replace the filter by a new, original one (HA010103).

When replacing the filter, please note the following:

- Unscrew the filter cap very carefully to avoid damaging the sensing element.
- Handling the filter might clog the pores. Use gloves to screw on the new filter.

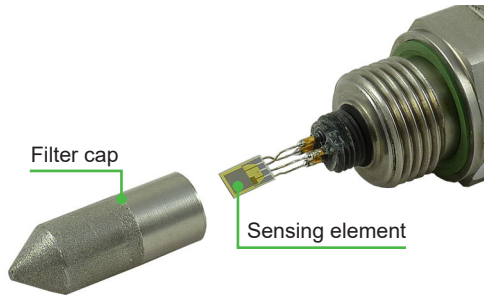

Fig. 8 EE371 filter and sensing element

7.4 Cleaning the Sensing Element

⚠ WARNING

- Never touch the sensing elements
- Any attempt to clean the sensing elements mechanically such as rubbing or brushing leads certainly to their irreversible damage.

Please refer to the “Cleaning the Instructions”, available online at the E+E Download-Centre.

7.5 Self-Diagnosis and Error Messages

Self-diagnosis via LED on the circuit board:

Power LED (green):

- flashing → EE371 is correctly powered / the microprocessor is active
- constantly lit → Electronics defect => please contact the manufacturer

Diagnostic LED (D1, blue):

- flashing → The sensing element is wet (condensation)
- constantly lit → The sensing element is damaged

Self-diagnostic via display (option):

- Error 1 → The dew point sensing element is damaged
- Error 2 → The sensing element is wet (condensation)
- Error 3 → The temperature sensing element is damaged
- Error 4 → Short circuit on the temperature sensing element

7.6 Repairs

i PLEASE NOTE

Repairs may only be carried out by the manufacturer. The attempt of unauthorised repair excludes any warranty claims.

8 Accessories

Description	Code
PCS10 Product Configuration Software (free download: www.epluse.com/pcs10)	PCS10
Product Configuration Adapter (available at www.epluse.com/ee371)	EE-PCA (with the EE-PCA connection cable HA011063)
Sampling cell ISO G 1/2" with quick connector	HA050102
Sampling cell NPT with bleed screw	HA050107
Sampling cell ISO G 1/2" for atmospheric dew point	HA050106
Basic sampling cell with ISO G 1/2" connector	HA050103
Basic sampling cell with NPT connector	HA050105

9 Technical Data

Measurands

Dew Point Temperature (Td)

Measuring range	-60...+60 °C Td (-76...+140 °F Td)
Accuracy ¹⁾	
Response time t_{90}	<5 min for step -5 °C Td (+23 °F Td) → -50 °C Td (-58 °F Td) <20 s for step -50 °C Td (-58 °F Td) → -5 °C Td (-23 °F Td)

1) Traceable to intern. standards, administrated by NIST, PTB, BEV, ...
 The accuracy statement includes the uncertainty of the factory calibration with an coverage factor k=2 (2-times standard deviation). The accuracy was calculated in accordance with EA-4/02 and with regard to GUM (Guide to the Expression of Uncertainty in Measurement).

Volume Concentration (Wv)

Measuring range @ 1 013 mbar (14.7 psi)	20...200 000 ppm
Accuracy @ 20 °C (68 °F) and 1 013 mbar (14.7 psi)	±(5 ppm + 9 % from measured value)



Outputs

Analogue

Two freely selectable and scaleable outputs ¹⁾ Td, Tf or Wv	0 – 10 V 4 – 20 mA (3-wire)	0 mA < I_L < 1 mA R_L < 500 Ω ¹⁾	I_L = load current R_L = load resistance
---	--------------------------------	--	---

1) Traceable to intern. standards, administrated by NIST, PTB, BEV, ...
 The accuracy statement includes the uncertainty of the factory calibration with an coverage factor k=2 (2-times standard deviation). The accuracy was calculated in accordance with EA-4/02 and with regard to GUM (Guide to the Expression of Uncertainty in Measurement).

General

Power supply class III  USA & Canada: Class 2 supply necessary, max. voltage 30 V DC	15 – 30 V DC
Current consumption , typ. @ 24 V DC	Voltage output Current output
Electrical connection 7-pole industrial plug wire cross-section cable outlet	40 mA / during auto-calibration: 100 mA 80 mA / during auto-calibration: 140 mA DIN VDE 0627 / IEC 61984 0.25...1 mm ² PG 11
Filter	Stainless steel sintered
Pressure working range	0...20 bar (0...300 psi) 0...100 bar (0...1 450 psi)
Temperature working range Medium (air) Electronics Display	-40...+70 °C (-40...+158 °F) -40...+60 °C (-40...+140 °F) -20...+50 °C (-4...+122 °F)
Storage condition	-40...+60 °C (-40...+140 °F)
Enclosure Material Protection rating	Aluminium die-cast (AlSi9Cu3) IP65
Electromagnetic compatibility	EN 61326-1 EN 61326-2-3 Industrial environment FCC Part15 Class B ICES-003 Class B
Conformity	 
Configuration and adjustment	PCS10 Product Configuration Software (free_download: www.epluse.com/pcs10) and configuration adapter

10 Conformity

10.1 Declarations of Conformity

E+E Elektronik Ges.m.b.H. hereby declares that the product complies with the respective regulations listed below:



European directives and standards.

and



UK statutory instruments and designated standards.

Please refer to the product page at www.epluse.com/ee371 for the Declarations of Conformity.

10.2 Electromagnetic Compatibility

EMC for industrial environment.

The sensor is a group 1 device and corresponds to class B.

10.3 FCC Part 15 Compliance Statement

This equipment has been tested and found to comply with the limits for a Class B digital device, pursuant to part 15 of the FCC Rules. These limits are designed to provide reasonable protection against harmful interference in a residential installation. This equipment generates, uses and can radiate radio frequency energy and, if not installed and used in accordance with the installation manual, may cause harmful interference to radio communications. However, there is no guarantee that interference will not occur in a particular installation. If this equipment does cause harmful interference to radio or television reception, which can be determined by turning the equipment off and on, the user is encouraged to try to correct the interference by one or more of the following measures:

- Reorient or relocate the receiving antenna.
- Increase the separation between the equipment and receiver.
- Connect the equipment into an outlet on a circuit different from that to which the receiver is connected.
- Consult the dealer or an experienced radio/TV technician for help.

10.4 ICES-003 Compliance Statement

This Class B digital apparatus complies with Canadian ICES-003.

Cet appareil numérique de la classe B est conforme à la norme NMB-003 du Canada.

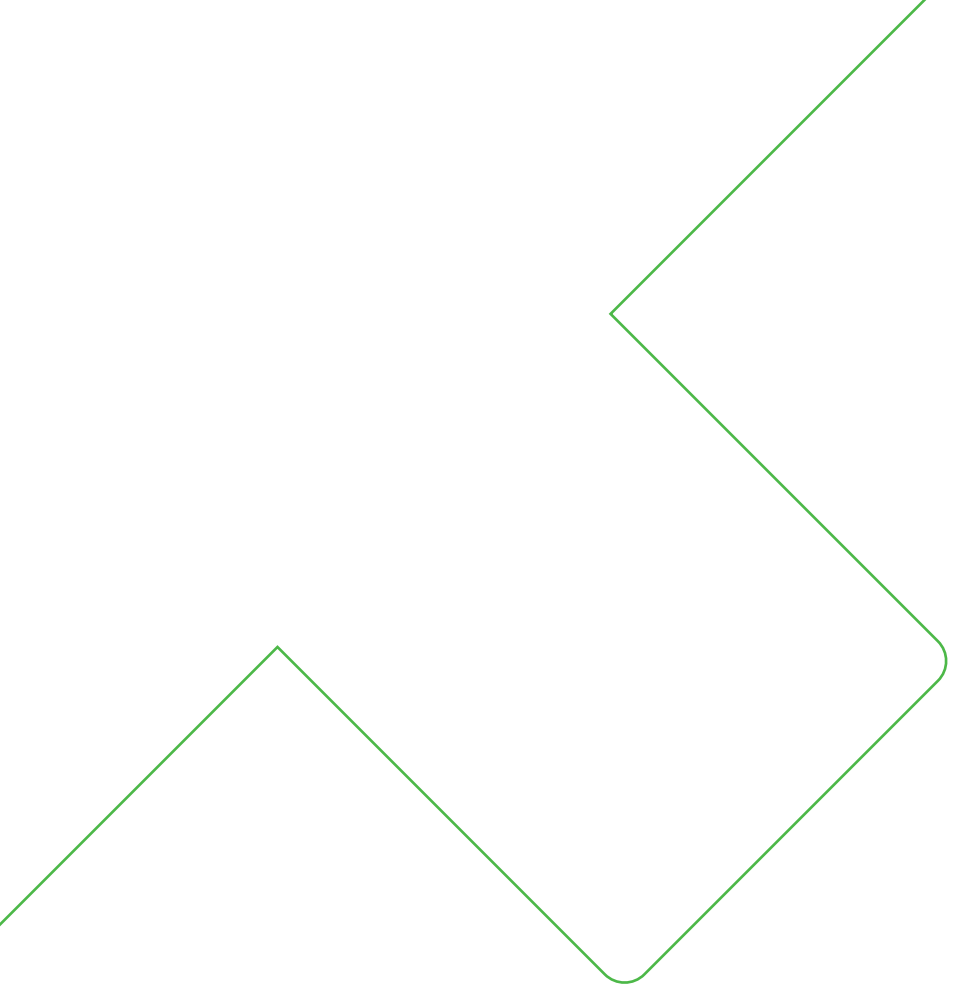

Company Headquarters &
Production Site

E+E Elektronik Ges.m.b.H.
Langwiesen 7
4209 Engerwitzdorf | Austria
T +43 7235 605-0
F +43 7235 605-8
info@epluse.com
www.epluse.com

Subsidiaries

E+E Sensor Technology (Shanghai) Co., Ltd.
T +86 21 6117 6129
info@epluse.cn

E+E Elektronik France SARL
T +33 4 74 72 35 82
info.fr@epluse.com

E+E Elektronik Deutschland GmbH
T +49 6171 69411-0
info.de@epluse.com

E+E Elektronik India Private Limited
T +91 990 440 5400
info.in@epluse.com

E+E Elektronik Italia S.r.l.
T +39 02 2707 86 36
info.it@epluse.com

E+E Elektronik Korea Ltd.
T +82 31 732 6050
info.kr@epluse.com

E+E Elektronik Corporation
T +1 847 490 0520
info.us@epluse.com



—
your partner
in sensor
technology.