

EE65

Air Velocity Transmitter for HVAC Applications

EE65 air velocity transmitters are ideal for accurate ventilation control applications. They are operating on an innovative hot film anemometer principle.

The E+E thin film sensor guarantees very good accuracy at low air velocity, which is not possible for conventional anemometers with commercial temperature sensors or NTC bead thermistors.

Moreover, the E+E sensor is much more insensitive to dust and dirt than all other anemometer principles. This means high reliability and low maintenance costs.

The EE65 are available with current or voltage output, the measuring range and the response time can be selected with jumpers by the user. Low angular dependence enables easy, cost-effective installation.

The configuration equipment allows air velocity adjustment of the sensor.



EE65 - B

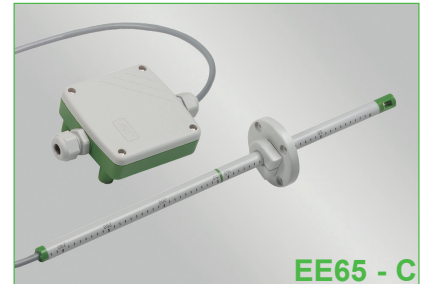

EE65 - C

Typical Applications

HVAC
process and environmental control

Features

low angular dependence
easy installation
adjustable to application requirements

Technical Data

Measuring values

Working range ¹⁾	0...10m/s (0...2000ft/min)
	0...15m/s (0...3000ft/min)
	0...20m/s (0...4000ft/min)
Output ¹⁾	0 - 10V -1mA < I _L < 1mA
0...10m/s / 0...15m/s / 0...20m/s	4 - 20mA R _L < 450 Ω
Accuracy at 20°C (68°F)	0.2...10m/s (40...2000ft/min) ±(0.2m/s / 40ft/min + 3 % of m. v.)
45 % RH and 1013hPa	0.2...15m/s (40...3000ft/min) ±(0.2m/s / 40ft/min + 3 % of m. v.)
	0.2...20m/s (40...4000ft/min) ±(0.2m/s / 40ft/min + 3 % of m. v.)
Response time τ ₉₀ ^{1) 2)}	typ. 4 sec. or typ. 0.7 sec. (at constant temperature)

General

Power supply	24V AC/DC ±20%
Current consumption	max. 150 mA
for AC supply	
for DC supply	max. 90 mA
Angular dependence	< 3% of measurement at Δα < 10°
Electrical connection	screw terminals max. 1.5 mm ² (AWG 16) ²
Cable gland	M16x1,5 cable Ø 4.5 - 10 mm (0.18 - 0.39")
Electromagnetic compatibility	EN61326-1
	EN61326-2-3
Housing material	Polycarbonate, UL94HB approved
Protecting class	Housing: IP65
	remote Probe: IP20
Temperature range	working temperature probe -25 ... +50°C
	working temperature electronic -10 ... +50°C
	storage temperature -30 ... +60°C
Working range humidity	5...95 % RH (non-condensing)



1) Selectable by jumper

2) Response time τ₉₀ is measured from the beginning of a step change of air velocity to the moment of reaching 90% of the step.

Dimensions (mm)

1 mm = 0.03937" / 1" = 25.4 mm

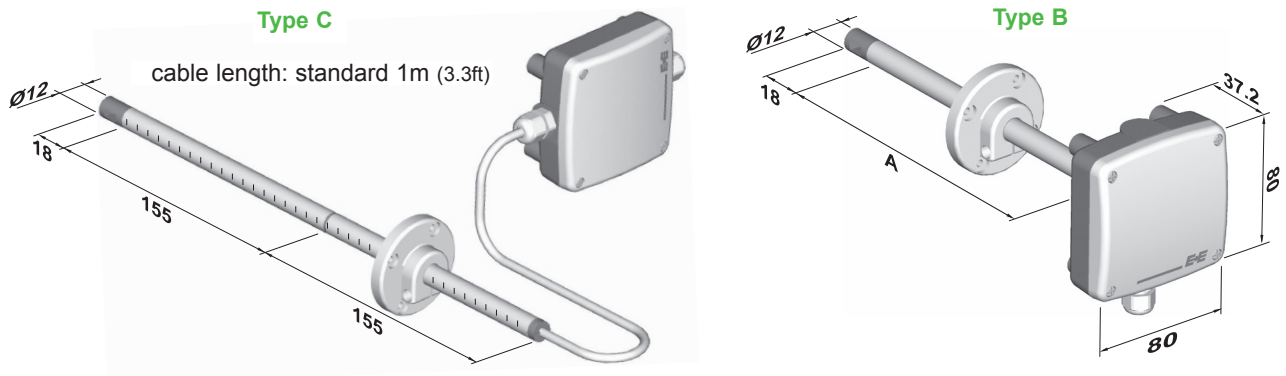

Connection Diagram

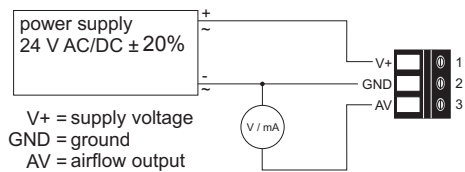

Ordering Guide

MODEL	HOUSING	PROBE LENGTH (see Dimensions: Length "A", Type B only)	CABLE LENGTH (Type C only)
velocity	(V) duct mounting	(B) 100mm (3.9")	(3) 1m (3.3ft) (no code)
	remote sensor probe	(C) 200mm (7.9")	(5) 2m (6.6ft) (K200)
		others	(x) 5m (16.4ft) (K500)
			10m (32.8ft) (K1000)
EE65-			

Order Example

EE65-VB5

model: velocity
housing: duct mounting
probe length: 200mm (7.9")

Scope of Supply

- EE65 Transmitter according ordering guide
- Cable gland
- Mounting flange
- Mounting kit
- Protection cap
- Operation manual
- Two self-adhesive labels for configuration changes¹⁾
- Test report according to DIN EN10204 - 2.2

1) see user guide at www.epluse.com/configuration-change

Accessories

Snap in - mounting flange for duct mounting
Product configuration adapter
Product configuration software
Power supply adapter

HA010205
siehe Datenblatt EE-PCA
EE-PCS (free download: www.epluse.com/configurator)
V03 (see data sheet "Accessories")